

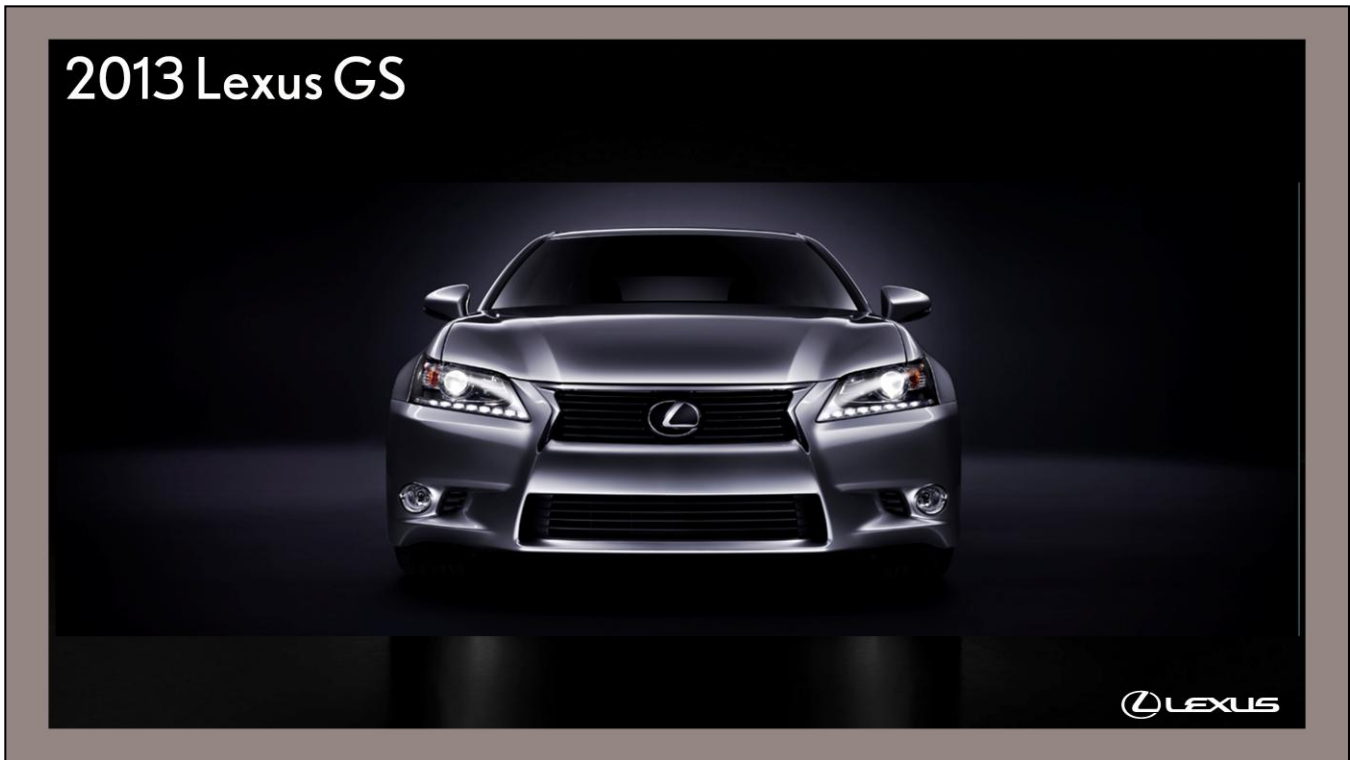

2013 LEXUS GS GS



2013 LEXUS GS GS



1ST GENERATION GS (1993–1997): THE PURSUIT OF INDIVIDUALITY

- The 1st-generation GS was recognized as a premium sedan that could challenge the best from Germany, which had already established a solid reputation in the marketplace.
- Giorgetto Giugiaro of Italdesign helped in the creation of GS.
- The design team stepped outside of the conventional Toyota design techniques and the confines of the conventional “domestic” or “foreign” frameworks.
- The platform shared suspension design and many drivetrain components with the Lexus SC 400 coupe and the Toyota Turbo Supra.

Engine type: 3.0-liter DOHC inline 6-cylinder
(shared with the Lexus SC 300 and Toyota Supra)

Transmission type: 4-speed automatic

Horsepower: 220 @ 5800 rpm

Torque: 210 lb.-ft. @ 4800 rpm

EPA fuel economy (city/hwy): 16/21 (1993)

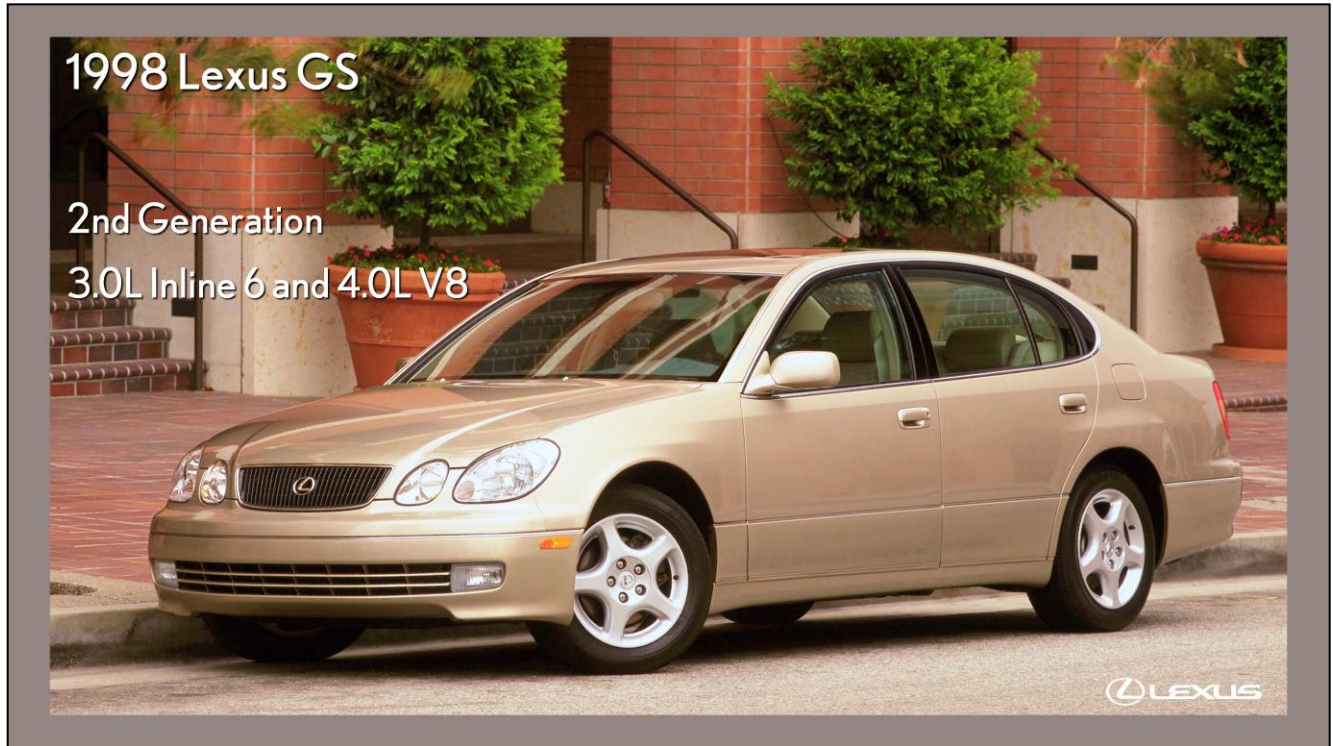

2ND GENERATION GS (1998-2004): THE PURSUIT OF SPEED

- For the 2nd-generation GS, Lexus achieve ultra-high-speed driving capabilities with a top speed of 155 MPH, exceeding the fastest German sedans and becoming “the world’s fastest sedan.”
- The platform developed for the 1st generation was further refined in the pursuit of the most stable yet efficient package for a RWD sedan.
- This platform was the basis for the development of the shorter & narrower Lexus IS (Altezza) sport sedan .
- Named “1998 Import Car of the Year” by *Motor Trend* and was selected by *Car and Driver* as one of the 10 Best Cars for three consecutive years, from 1998 to 2000.

Engine type: GS 300: 3.0-liter DOHC inline 6-cylinder (shared with Supra & IS 300)
GS 400: 4.0-liter DOHC V8 (shared with LS 400)

Transmission type: 5-speed automatic

Horsepower: 225 @ 6000 rpm (GS 300)
300 @ 6000 rpm (GS 400)

Torque: 220 lb.-ft. @ 4000 rpm (GS 300)
310 lb.-ft. @ 4000 rpm (GS 400)

EPA MPG (city/hwy): 17/23 (GS 300);
15/21 (1998 GS 400)

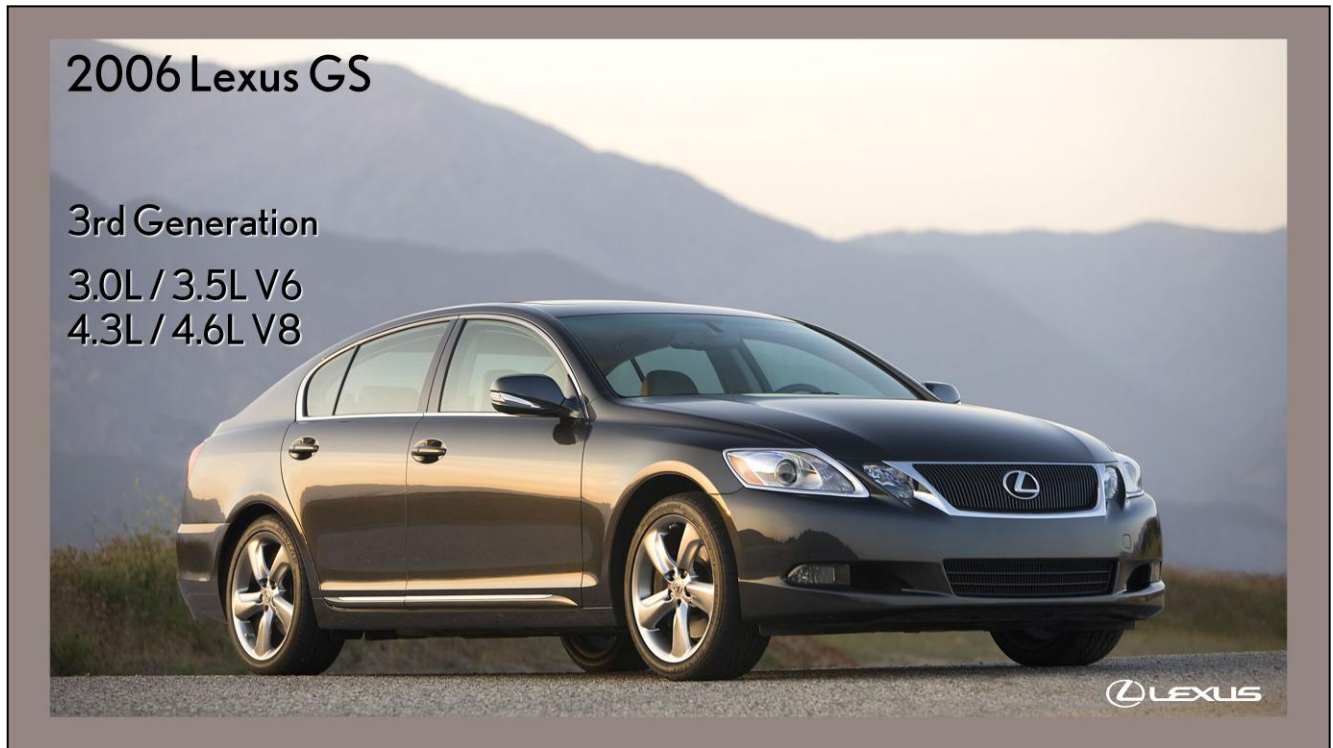

3RD GENERATION GS (2005-2011): THE PURSUIT OF ADVANCED REAR-WHEEL-DRIVE TECHNOLOGY

- The 3rd-generation model was based on the concept of developing an “innovative sedan” that incorporated state-of-the-art technology in powertrain, suspension, and interior electronics.
- This new model completely overturned stereotypes by delivering controlled handling, brisk acceleration, very low emissions, and high fuel efficiency unmatched by the German 3.
- This platform was again the basis for a new IS series one model year later.

Engine type: 3.0/3.5-liter DOHC V6 (GS 300/GS350)
4.3/4.6-liter DOHC V8 (GS 430/GS460)

Transmission type: 5-speed automatic
5-speed automatic

Horsepower: 220 @ 5800 rpm (GS 300) / 303 @ 6200 rpm (GS 350)
300 @ 5600 rpm (GS 430) / 342 @ 6200 rpm (GS 460)

Torque: 220 lb.-ft. @ 3800 rpm (GS 300) / 274 lb.-ft. @ 3600 rpm (GS 350)
325 lb.-ft. @ 3400 rpm (GS 430) / 339 lb.-ft. @ 3600 rpm (GS 460)

EPA MPG (city/hwy): 16/23 (GS 300);
16/22 (2005 GS 430)



3RD GENERATION (2007–2011): THE PURSUIT OF REAR-WHEEL-DRIVE HYBRID TECHNOLOGY

- Unveiled at the 2005 New York International Auto Show, the hybrid GS 450h joined the GS line in 2006 for the 2007 model year.
- Until the development of the 3rd-generation Lexus GS, hybrid vehicles were only known for being fuel-efficient and environmentally friendly.
- First mass-produced rear-wheel-drive hybrid, and first luxury hybrid
- Naturally-aspirated 3.5-liter 2GR-FSE 3.5L V6 mated to electric motor/generators in continuously variable transmission.
- Lexus Hybrid Drive system combined electric motors with the gasoline engine for a Super Ultra Low Emission Vehicle (SULEV II) rating.
- Total output of 339 hp (253 kW)
- 0–60 mph acceleration time of 5.2 sec
- top speed >130 MPH.

Engine type: 3.5-liter DOHC V6

Transmission type: Electronically-controlled Continuously Variable Transmission

Total system horsepower: 340 @ 5800 rpm

EPA fuel economy (city/hwy): 22/25

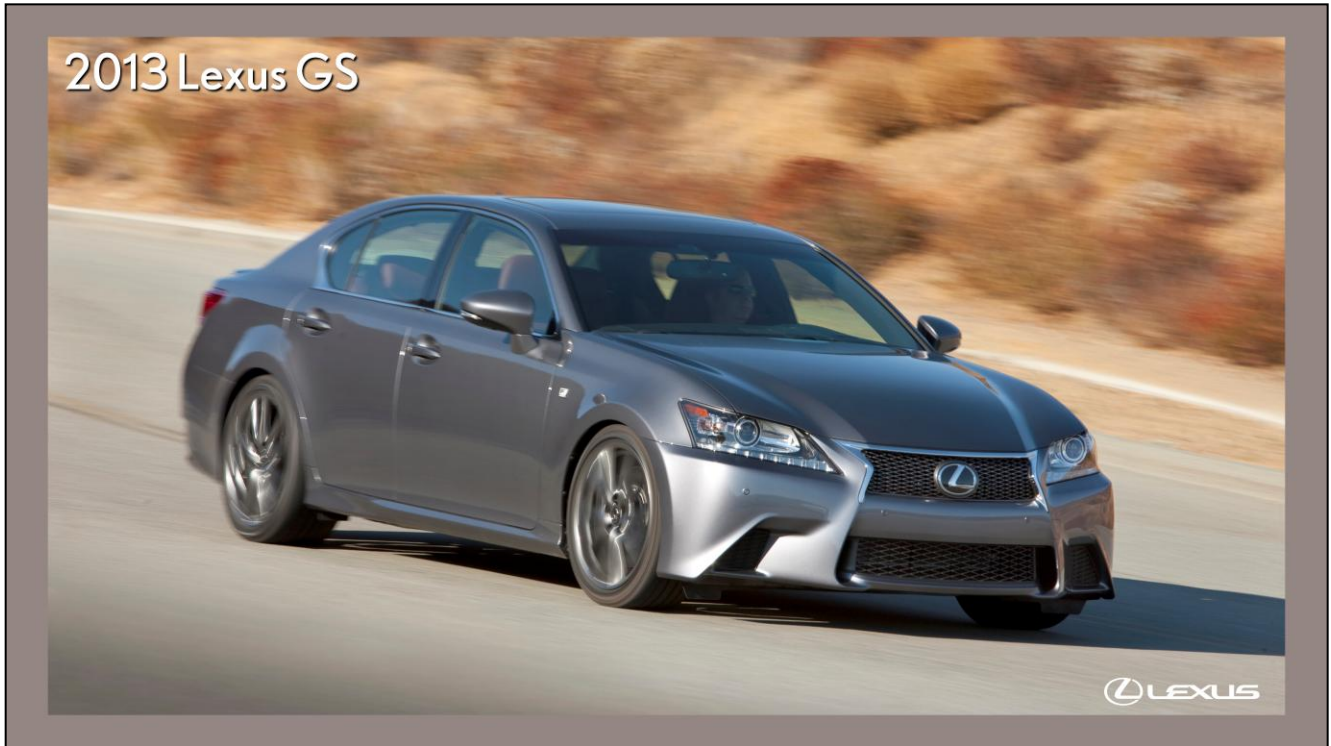

THE OBJECTIVE FOR THE 4TH-GENERATION GS: AN EMOTIONALLY INTRIGUING LEXUS DRIVING EXPERIENCE

- The next-generation GS must complete its evolution to becoming a full-fledged Grand Touring Sedan.
- The 4th-generation GS is the initial model in the next-generation Lexus lineup and is designed to deliver an emotionally intriguing driving experience.
- The evolved driving performance created in this new model will be carried over to future Lexus models as the essential driving taste of the Lexus brand that inherits the DNA of the LFA.

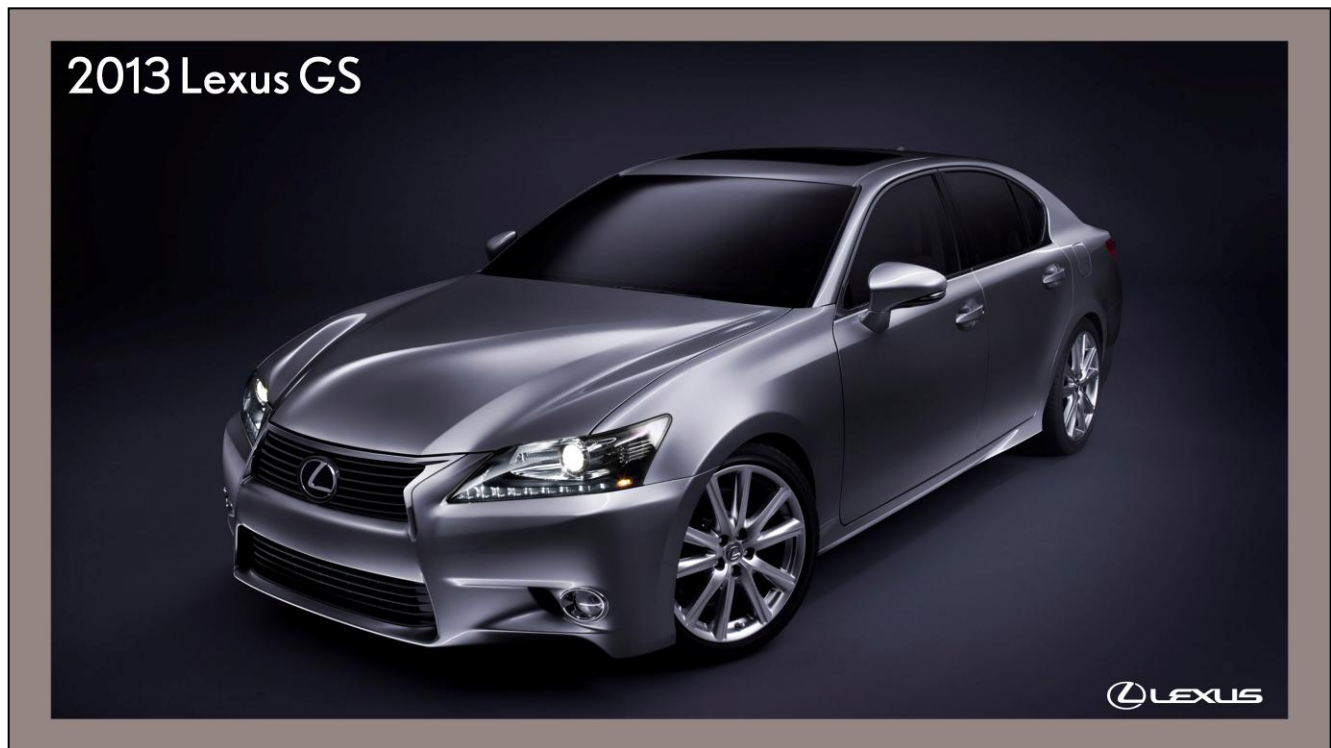

CURRENT STATE OF THE LEXUS BRAND

- Mid-size sedans are the core of any Luxury brand.
- European premium brands have dominated the mid-size luxury market for many years.
- The luxury market was affected by the financial crisis (Lehman Shock) that began in 2008 and suffered a temporary decline, but recently the market has begun to steadily recover.
- One trend that has emerged is the downsizing from the large vehicle class, which in turn is accelerating the expansion of the mid-size luxury market.
- The Lexus GS has continuously enhanced its performance as a Grand Touring Sedan and has aggressively challenged itself to achieve the most cutting-edge technology with its L-finesse design philosophy.
- Because of this trend, each premium brand is updating its core model in the mid-size luxury class and further honing the unique strengths of these models.

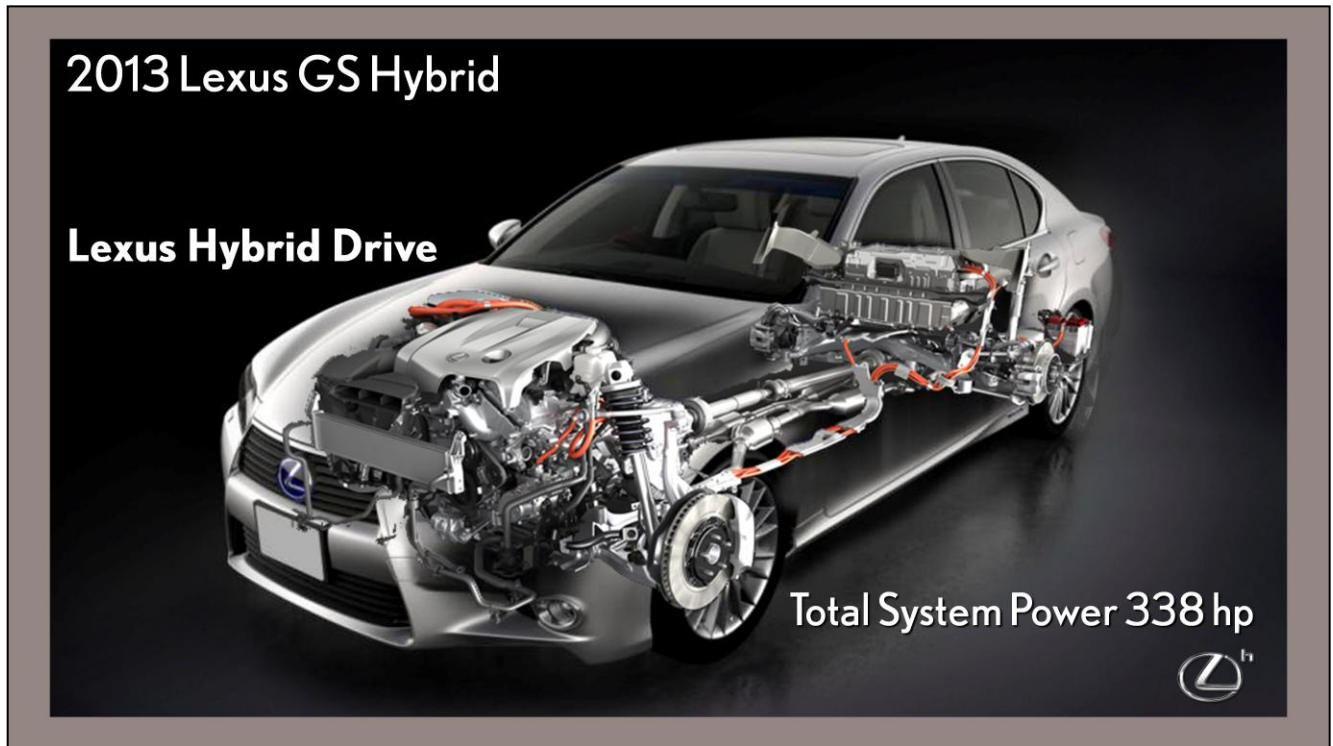

2013 LEXUS GS HYBRID

- Revised 6th-generation corporate hybrid system incorporates advanced low-emission and high-efficient features recently introduced in other models.
- ICE output = 286 hp (213 kW)
 HV Battery output = 52 hp (39 kW)
 Total System Power = 338 hp (252 kW)
- This new, more powerful, hybrid system is dramatically more efficient, and replaces the V* as the top model in the line.
- The development team challenged itself to engineer a top-level hybrid luxury sedan with the type of acceleration characteristics that stimulates the human emotion.
- Exceptional driving performance is made possible because of the vast expertise we have in hybrid system developments.



FOUR AREAS OF FOCUS FOR THE NEW GS

INNOVATIVE PACKAGING

- Interior space that satisfies the core requirements of a luxury sedan
- An integrated feel between the vehicle and driver that makes driving fun
- Ample cargo space for long journeys

SYMBOLIC DESIGN

- A shape that gives the feeling of outstanding driving performance
- Establishes the “spindle” grille
- Shows the future design of all Lexus interiors

MAXIMIZED FUN TO DRIVE

- Outstanding handling performance with evolved sharpness
- Lexus Dynamic Handling 4WS system provides the ultimate in handling ability

EMOTIONAL ECONOMY

- Hybrid system that blends the two elements of “calmness” and “movement”
- Excellent fuel efficiency and environmental performance

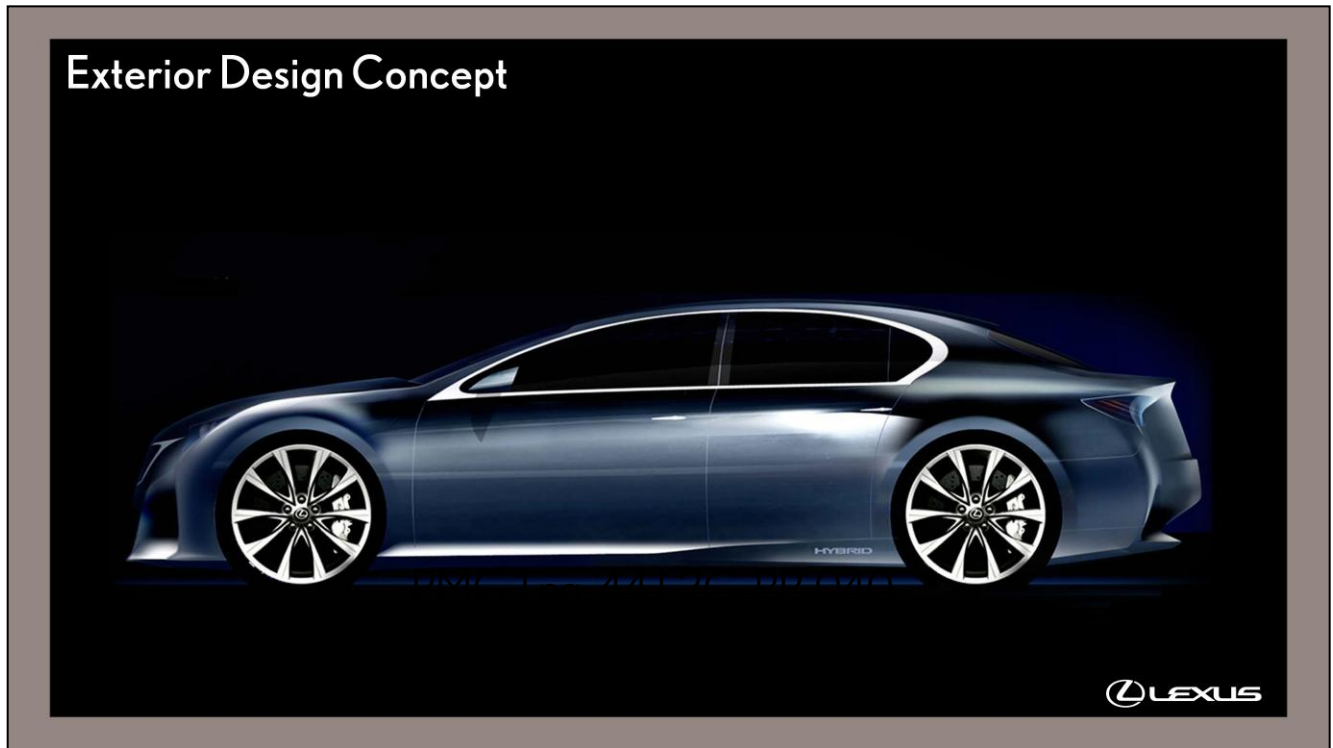

EXTERIOR DESIGN CONCEPT

- The challenge was to create an unequivocal sense of presence as the Lexus Grand Sedan.
- To achieve this, it was necessary to design a front mask with a stunning, symbolic image (the “spindle grille”) to clearly identify it as a Lexus.
- In the past, the grille was clearly divided into upper and lower sections by the bumper.
- The new design is bold yet elegant and exudes a sense of individuality
- It will be adopted throughout the Lexus brand as a design that symbolizes the Lexus identity.

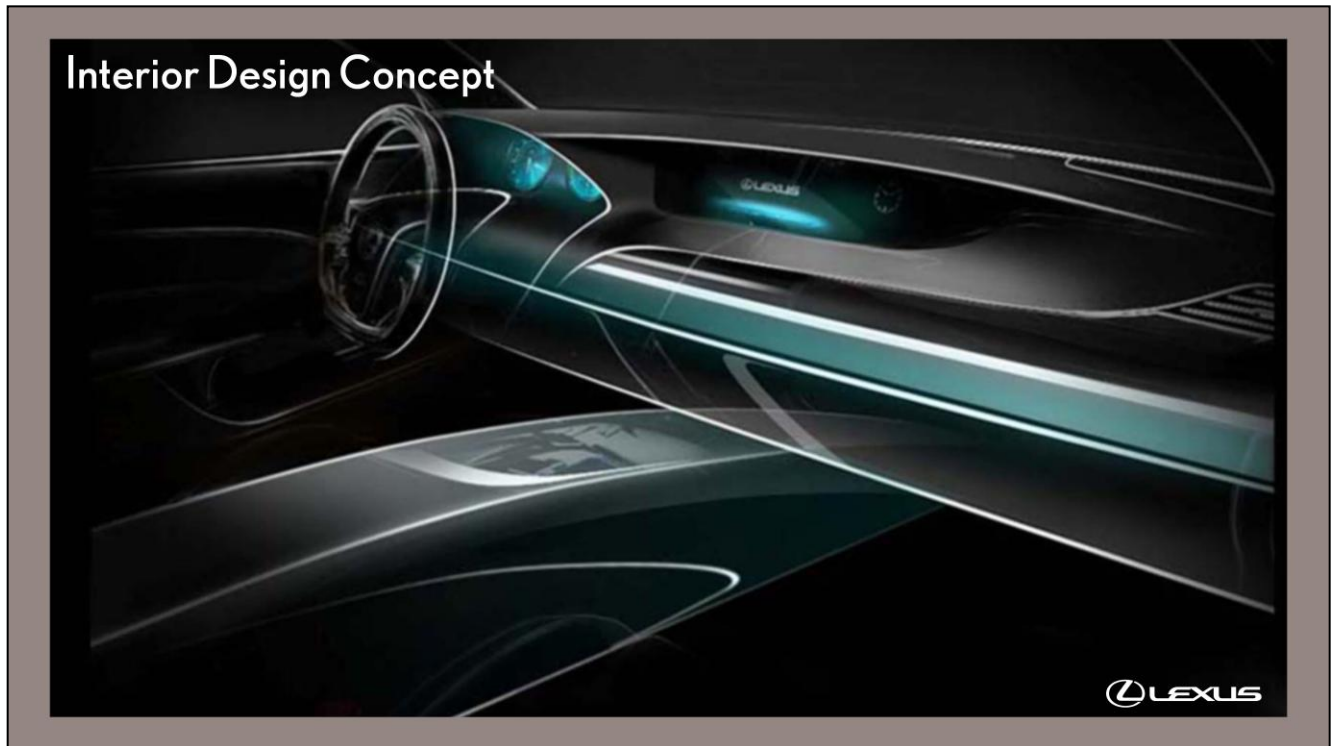

INTERIOR DESIGN CONCEPT

- Creates a space that always gives a sense of excitement and the anticipation of driving the moment you open the door.
- Provides space where the driver can immediately understand all the functions and how they operate as soon as he or she sits down.
- With the aim to achieve this, the development team returned to the Human Machine Interface (HMI) concept advocated by Lexus and began by rebuilding a “human-centered interior” to incorporate technology that anticipates human emotions, rather than space in which humans must adapt to the machines.
- The display zone, which includes the meters, etc., was clearly separated from the operation zone, centered around the Remote Touch Interface that allows the driver to operate the vehicle with a natural posture and minimal movement of the driver’s line of sight.
- A feeling of openness is created by the instrument panel’s horizontal line. The wide horizontal instrument panel has a powerful yet simple design and gives a sense of stability.

SUBSTANCE



SUBSTANCE



MATERIALS

- Seat materials are available in a wide variety of colors that befits each grade's interior image:
 - Base grade seat material has round perforation on main portion of seat.
 - Genuine semi-aniline leather seat upholstery on Luxury models.
 - Diamond-shaped perforation exclusive to F SPORT seats for an aggressiveness look.
- Five types of artistically designed trim coordinate with the interior color variations.
- Pronounced stitching is applied in colors that contrast with the leather upholstery.
- Stitched, padded, materials upholster the top of the instrument panel, the center console knee area, and front center armrest

CRAFTSMANSHIP

- Lexus Premium Analog Clock gives a high-quality feel befitting a luxury sedan:
 - Looks like a fine metal carving.
 - Clock illuminates the instant the door is unlocked, welcoming the passengers inside.
 - Illumination gradually fades when exiting the vehicle to leave an impression of time well spent..



THE ESSENCE OF THE GS 350

Well-equipped with the following standard features:

- 306 HP 3.5-liter DOHC V6 engine
- 6-Speed sequential shift automatic transmission
- Drive Mode Select, Paddle Shifters
- 17" alloy wheels
- Bi-Xenon headlamps with LED Daytime Running Lights
- SmartAccess keyless entry and push-button engine start system
- One-touch open/close moonroof
- 10-way power driver and front passenger seats
- Perforated leather seats
- Electronic Parking Brake with AUTO and HOLD features
- AM/FM/DVD with HD radio, 5.1 surround sound with 12-speakers, Advanced Bluetooth, Satellite radio
- Vehicle Dynamics Integrated Management (VDIM) system integrates and manages ABS, BA, EBD, VSC and Electric Power Steering (EPS)

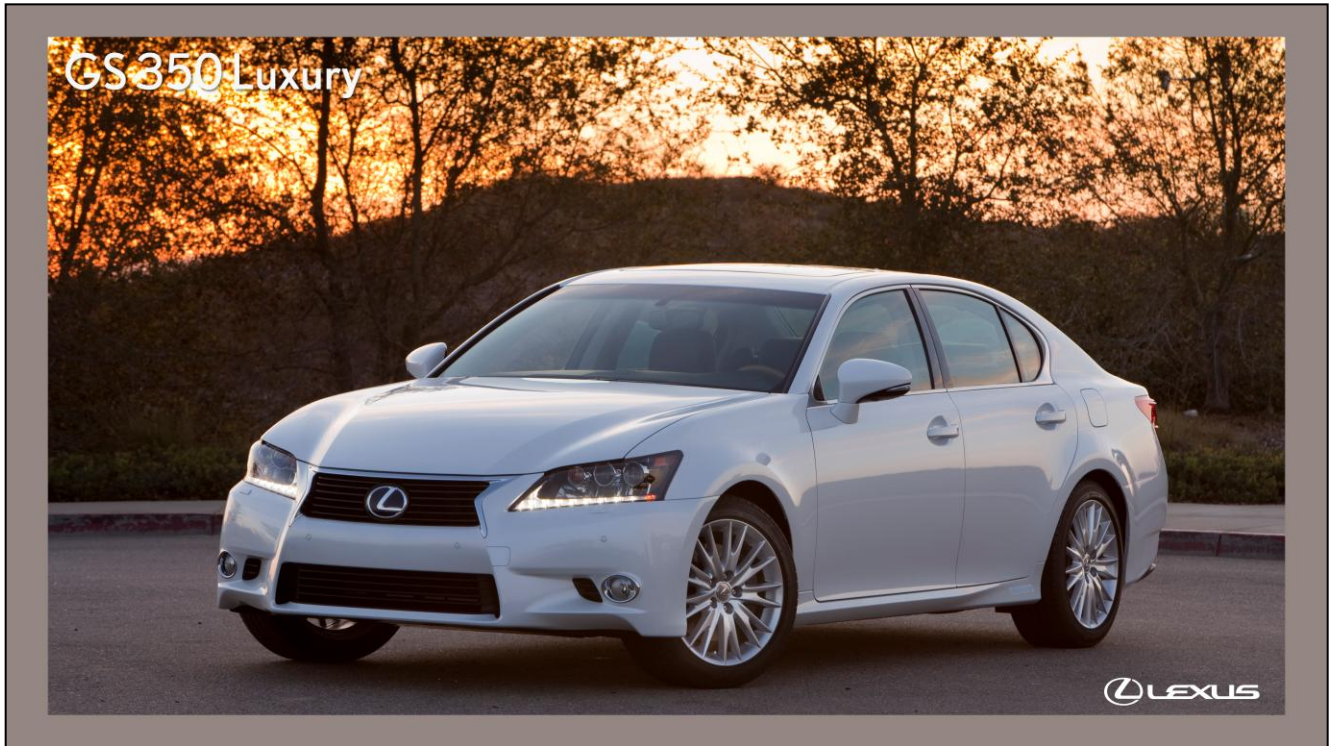

LUXURY PACKAGE EVOKES OWNER'S PRIDE

Luxury Package adds the following to GS 350:

- 18" split-spoke alloy wheels
- Adaptive Front lighting System (AFS)
- Adaptive Variable Suspension
- Semi-aniline leather seats
- High-gloss Linear Espresso wood interior trim
- Wood & leather steering wheel
- 18-way power front seats (includes power mid-back, side bolsters, thigh support, 4-way lumbar)
- Front passenger seat memory
- 3-zone air conditioning
- Rear audio controls
- Rear manual side sun shades



THE F SPORT PACKAGE AND ITS EXCEPTIONAL DRIVING PERFORMANCE

F SPORT adds or replaces the following to GS 350 Luxury:

- Sport front bumper and rear lower valence, unique mesh grille inserts
- Rear lip spoiler
- F SPORT badging on ft. fenders
- 19" staggered-width alloy wheels P235/40 R19 ft./ P265/35 R19 rr. summer tires (RWD)
- P235/40R19 all-season tires (AWD)
- F SPORT suspension tuning / F SPORT-tuned Adaptive Variable Suspension (AVS)
- Lexus Dynamic Handling w/ Variable Gear Ratio Steering (VGRS) (RWD)
- Larger front brake rotors and calipers with performance pads
- 16-way power sport driver seat (includes power side bolsters, thigh support, 4-way lumbar)
- Unique perforated leather trim
- Unique F SPORT interior treatment
- Perforated leather-wrapped steering wheel and shift knob
- Aluminum interior trim and pedals



HYBRID MODEL COMBINES THE PERFORMANCE WITH EFFICIENCY

Well-equipped with the following features:

- 3.5-liter DOHC V6 Atkinson cycle engine
- Two permanent magnet electric motor/generators
- Electronically-controlled Continuously Variable Transmission with intelligence and 2-stage torque multiplication for high speed performance
- EPA fuel economy: 29 / 34 / 31 MPG (city / hwy / comb)
- Drive Mode Select
- Electronic Parking Brake with AUTO & HOLD features
- 17" alloy wheels
- LED headlights
- SmartAccess keyless entry and push-button engine start system
- 10-way power driver and front passenger seats
- Zenith Black interior trim
- Perforated leather seats
- AM/FM/DVD with HD radio, 5.1, 12-speaker surround sound, Advanced Bluetooth, satellite radio
- Vehicle Dynamics Integrated Management (VDIM) system integrates and manages ECB, ABS, BA, EBD, VSC and Electric Power Steering (EPS)



PACKAGES & OPTIONS

- Premium Package (GS 350/450h only – not F SPORT):
 - Heated/ventilated front seats
 - Power rear sunshade
 - Rain-sensing wipers
- 18" alloy wheels with all season tires (GS 350/450h only)
- Mark Levinson Premium Surround Sound system with 17 speakers
- Lexus HDD navigation system with 12.3" high-resolution screen
- Lexus Dynamic Handling (LDH) System with Dynamic Rear Steering (DRS)
- Blind Spot Monitor
- Head-Up Display (HUD)
- Heated rear seats
- Intuitive Park Assist (IPA)
- Lane Keep Assist (LKA) using active steering with Lane Departure Warning (LDW)
- Night Vision system
- Pre-Collision System (PCS) with Driver's Eyes Monitor and Adaptive Cruise Control

NAVIGATION PACKAGE

- Navigation System
- 12.3-inch high-resolution split-screen multimedia display
- Compatible mobile-phone integration
- Enhanced *Bluetooth* technology
- Lexus Enform Application Suite with DestinationAssist, eDestination; Facebook location check-in; Yelp; voice-recognition application support including Bing, OpenTable, MovieTickets.com, Pandora and iHeart Radio. Subscription required
- NavTraffic,TM NavWeatherTM and Sports and Stocks. Subscription required. 90-day trial subscriptions included

COLD WEATHER PACKAGE

(standard on GS 450h)

- Heated steering wheel
- Enhanced interior heater
- Headlamp washers
- Windshield-wiper deicer
- Water-repellent front-door glass

INDIVIDUAL OPTIONS

- Mark Levinson 17-speaker, 835-watt (all channels driven @ less than 0.1% total harmonic distortion)
Premium Surround Sound Audio System with 7.1-channel architecture, digital amplifier and GreenEdgeTM speaker technology
- Pre-Collision System (PCS) includes Driver Attention Monitor with closed-eye detection, all-speed Dynamic Radar Cruise Control
- Lane Keep Assist with Lane Departure Warning
- Lexus Night View System

- Blind Spot Monitor System
- Heads-up Display
- Intuitive Parking Assist
- Lexus Dynamic Handling System including Dynamic Rear Steering (GS350 F Sport RWD)
- 18-inch split-five-spoke alloy wheels with all-season or summer tires (Base and Premium Package only)
- Heated rear seats (Luxury Package)
- LED headlamps



STABILITY & CONTROL IN DRIVING

- Stiffened body structure so suspension can be tuned for improved feedback and feel.
- Increase rear grip & stability for enhanced handling.
- Enhance vehicle responsiveness for improved steering feedback.
- Improve stabilizer bushings for better roll stiffness.
- Improve anti-dive/anti-squat characteristics.

Computer-Aided Analysis (CAA)

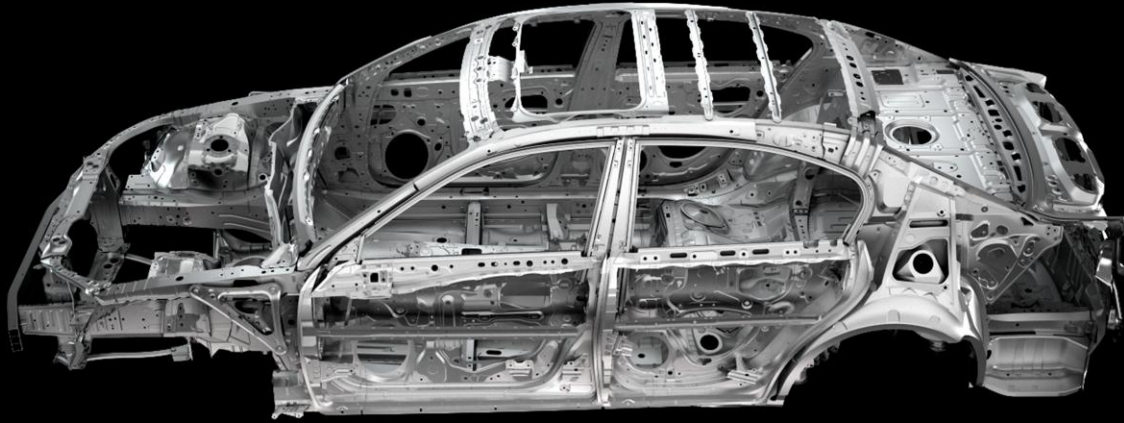

LEXUS

STABILITY & CONTROL IN DRIVING

- Stiffen body structure so suspension can be tuned for improved feedback and feel.
- Increase rear tire grip for enhanced handling.
- Enhance vehicle responsiveness for improved steering feedback.
- Improve stabilizer bushings for better roll stiffness.
- Improve anti-dive/anti-squat characteristics.

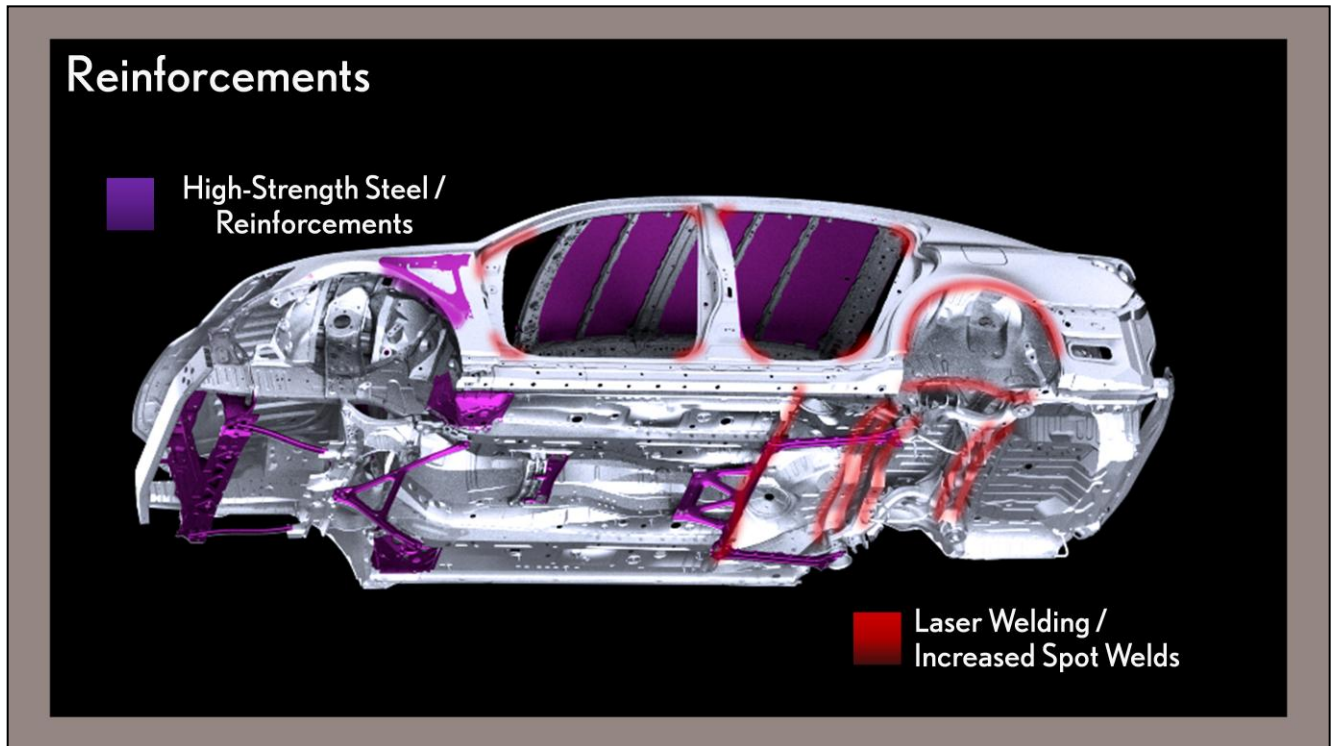

BODY STRUCTURE

- Increased body rigidity enhances handling stability.
- CAA & CAE used to manufacturing a highly rigid body structure.
- new GS responds more accurately than ever before to driver input.

ENHANCED BODY RIGIDITY

- Analysis of body distortion during steering was conducted using Computer-Aided Analysis (CAE), and structures were optimized using Computer-Aided Engineering (CAE).
- focusing on areas subject to high stress (red areas in illustration), adding increased reinforcements to enhance body rigidity.

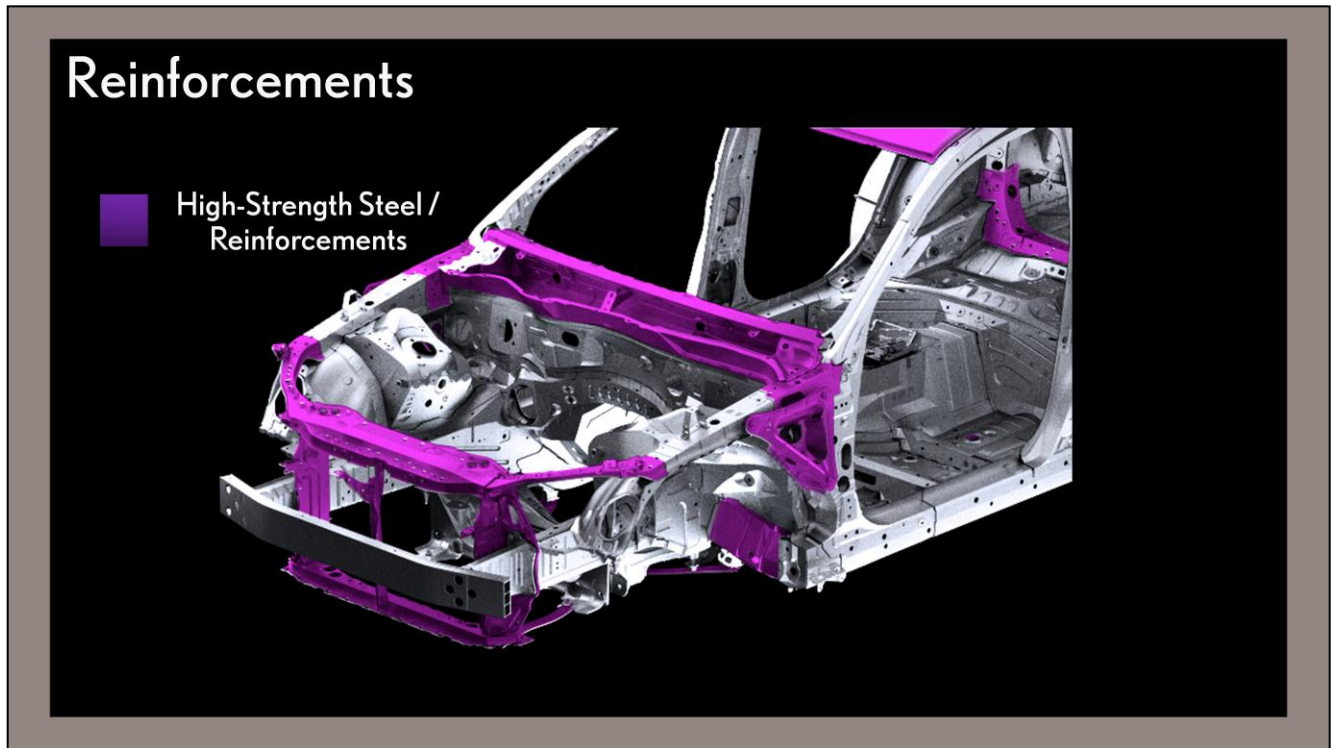

COWL SIDE BRACE

- cowl side brace increases rigidity of front suspension & steering mounts for handling stability.
- bracing A-pillar to apron member enhance steering response.
- Deformable bead shapes absorb energy in case of collision.

UNDERBODY STIFFNESS

- shape of the radiator support & rear underbody improve body stiffness.
- extensive underbody bracing stiffens the platform to improve driver feedback.

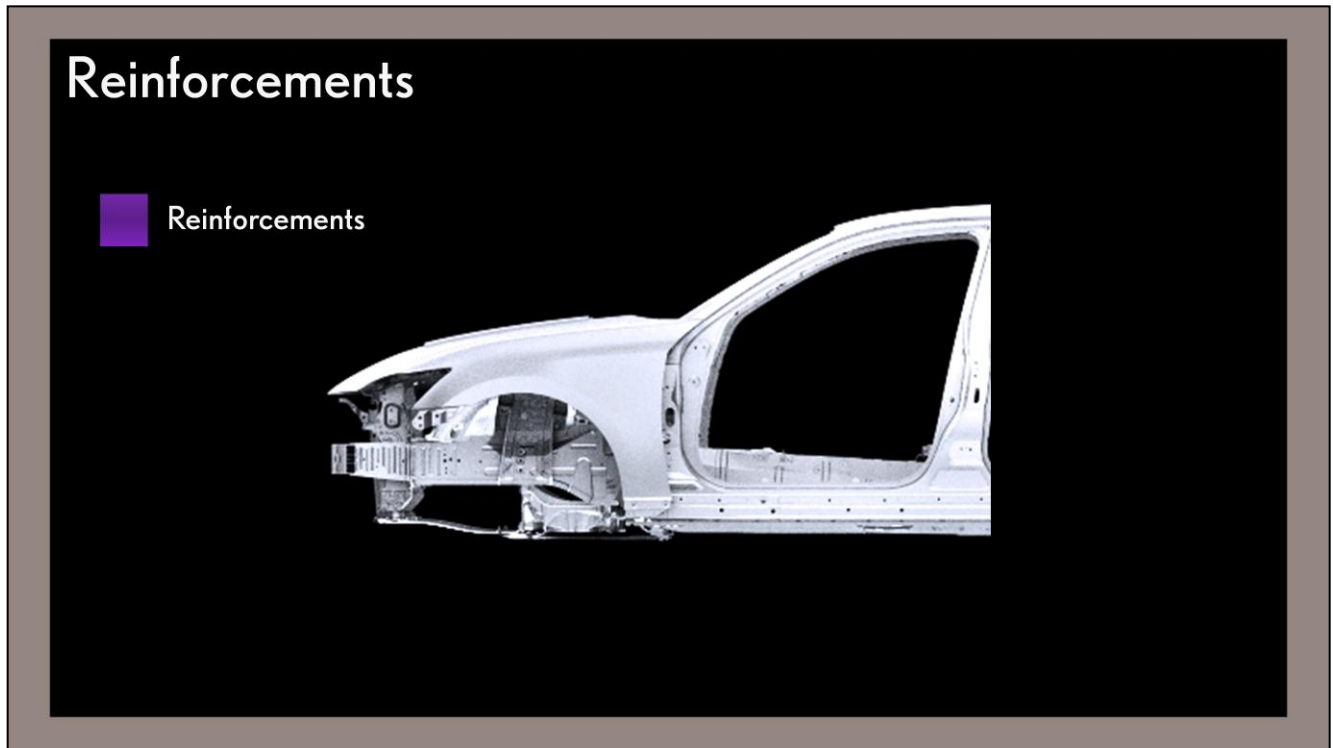

COWL SIDE BRACE

- cowl side brace increases rigidity of front suspension & steering mounts for handling stability.
- bracing A-pillar to apron member enhance steering response.
- Deformable bead shapes absorb energy in case of collision.

UNDERBODY STIFFNESS

- shape of the radiator support & rear underbody improve body stiffness.
- extensive underbody bracing stiffens the platform to improve driver feedback.

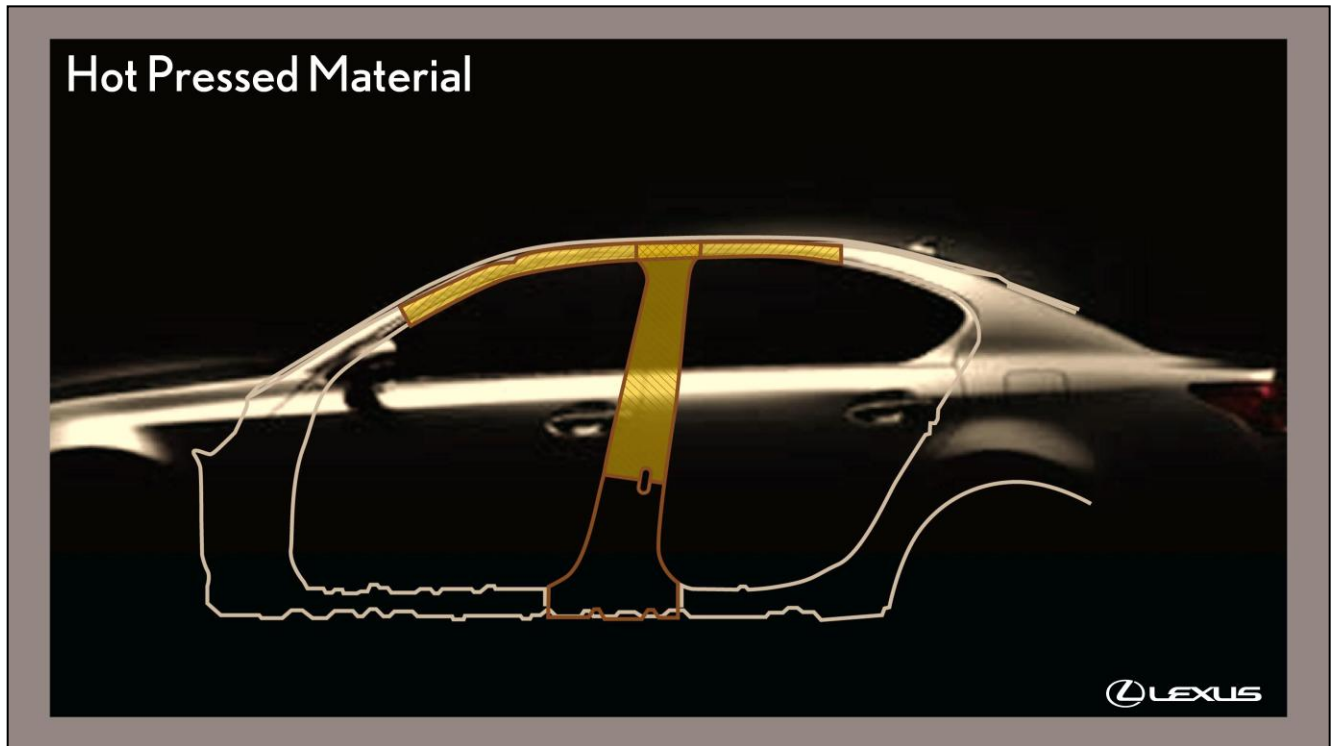

SIDE-MEMBER FRAME WITH LEXUS' FIRST HOT PRESSED MATERIAL

- Special ultra-high strength steel alloy used in the side-member panels.
- This steel is so stiff it cannot be easily stamped cold (room temp);
- Electric current is used to heat the blanks for hot-pressing
- Maintains high strength in the critical joint between B-pillar and roof side rails with a simpler structure that is lighter in weight.

Exterior Weight Reduction

Upperbody

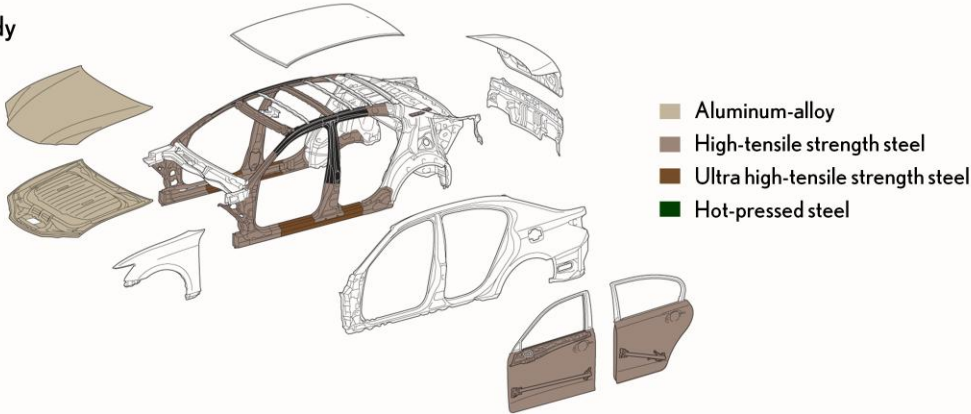

	Total Mass	High-tensile steel	Aluminum-alloy
Upperbody	529 lb. (240 kg)	146 lb. (66 kg)	24 lb. (11 kg)
Underbody	375 lb. (170 kg)	218 lb. (99 kg)	-
TOTAL	904 lb. (410 kg)	364 lb. (165 kg) 40.2%	24 lb. (11 kg) 2.7%



LIGHTWEIGHT BODY STRUCTURE

Lightweight, high-strength, upperbody:

- High-tensile steel sheet & hot pressed steel account for **40.2%** of the body mass
- Aluminum constitutes **2.7%**

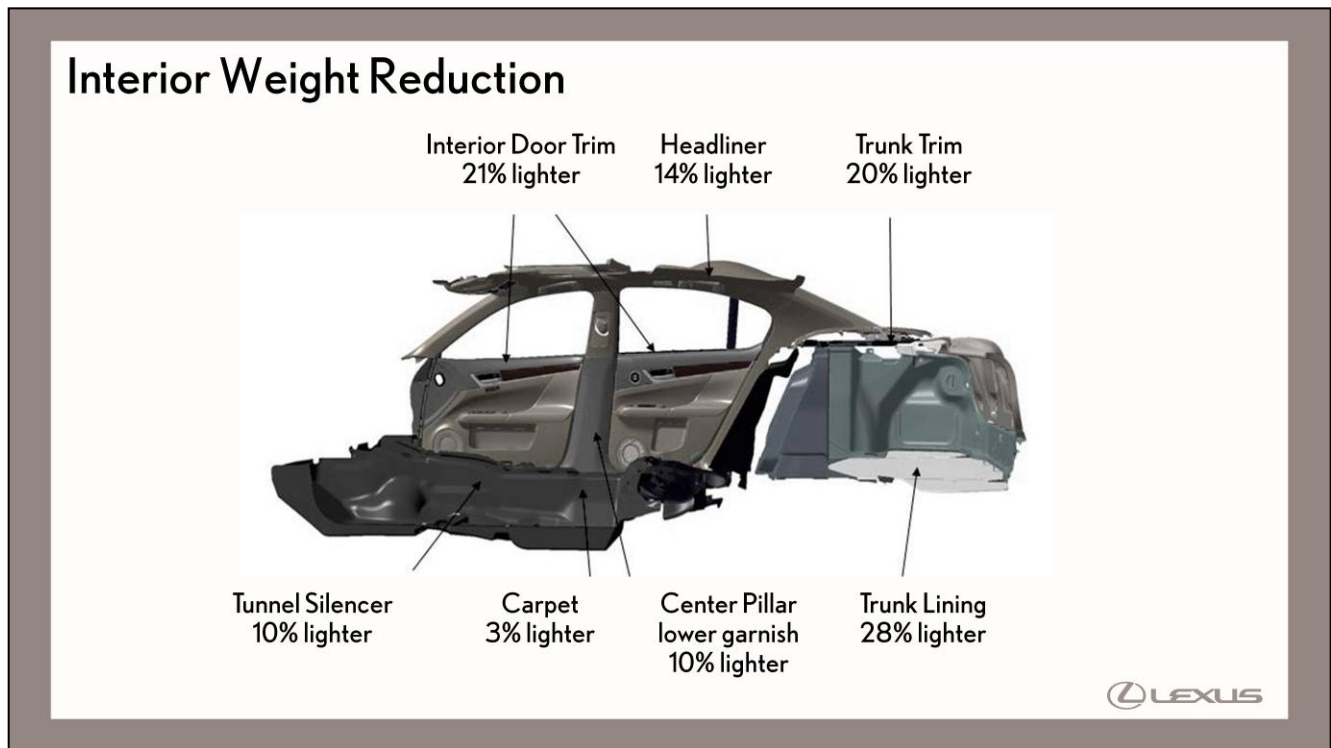

LIGHTER-WEIGHT INTERIOR TRIM

A 10% reduction in total weight of the overall interior compared to the previous model is achieved by implementing the following:

DOOR TRIM 21%

- Upper trim material changed.
- Lower board material changed.

HEADLINER 14%

- Basic material and ceiling upholstery changed.

TRUNK TRIM 20%

TRUNK 28%

- Tool tray configuration changed from a center box to a combination of a side box and bead pad.

TUNNEL SILENCER 10%

CARPET 3%

- Gap plugging material used in the tunnel area changed.

CENTER PILLAR LOWER GARNISH 10%

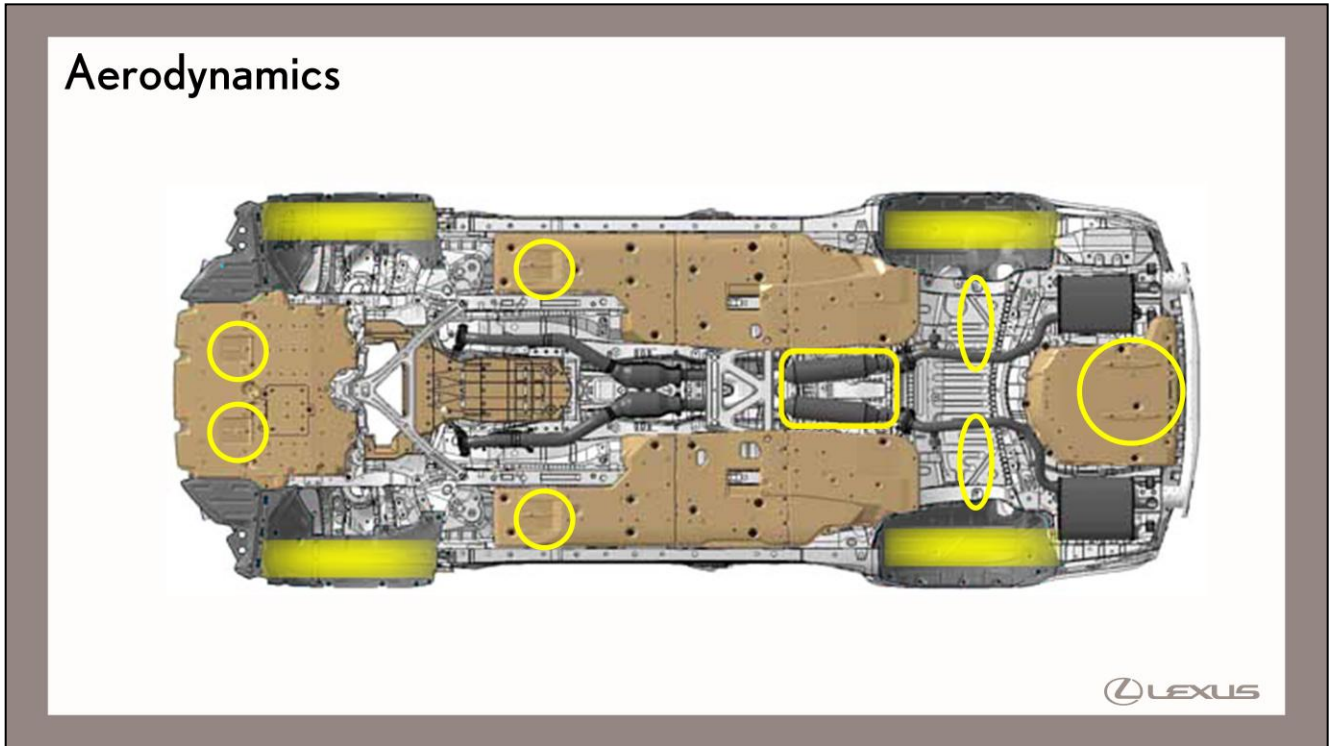

AERODYNAMIC IMPROVEMENT MEASURES UNDERBODY

- To smooth underbody airflow, a cover and aero-stabilizing fins have been added.
- Engine undercover and aero-stabilizing fins help to control air turbulence.
- Transmission undercover contributes to flattening the underbody.
- Underbody cover and aero-stabilizing fins have been added to smooth airflow.
- Rear-floor undercover and aero-stabilizing fins smooth the passage of air across the underbody and out the rear of the vehicle.
- A groove is provided in the fender liners, so the air flows over the tire in an aerodynamic manner.

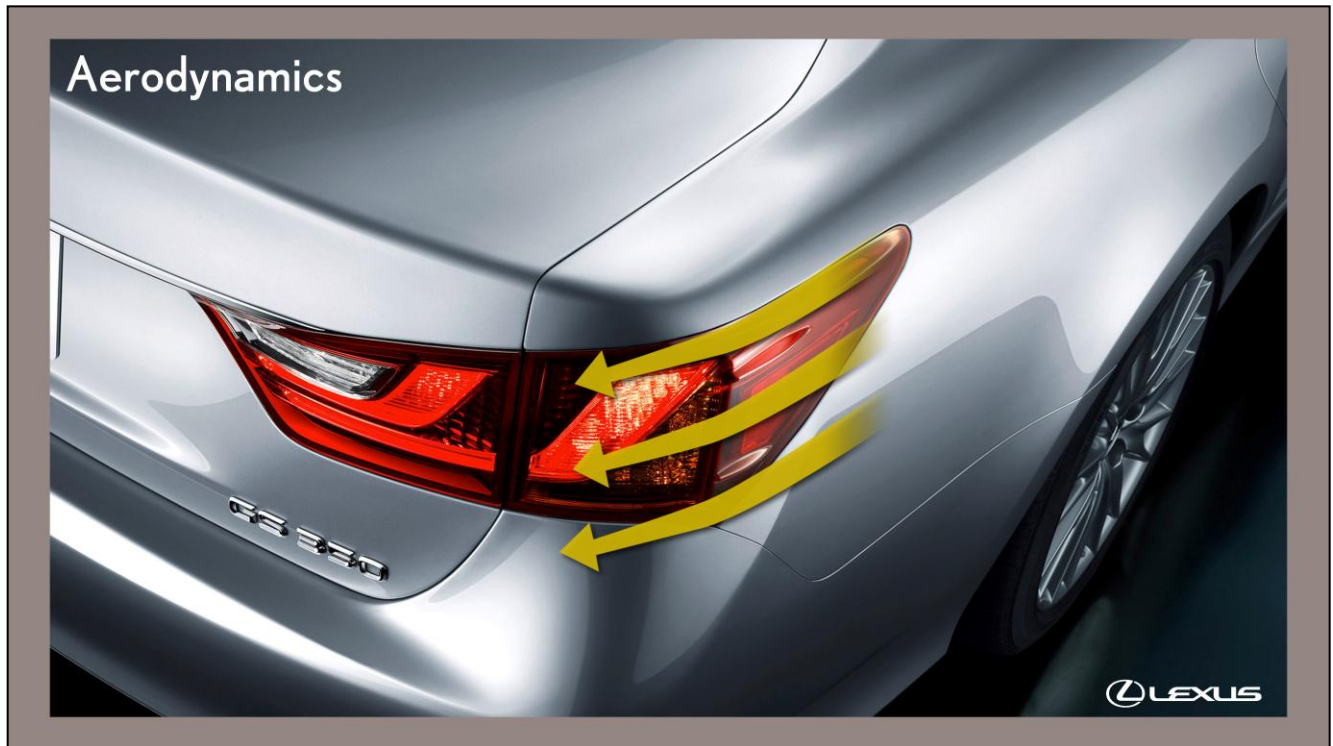

AERODYNAMIC IMPROVEMENT MEASURES: REAR

- Angle of the rear bumper lower section is set at 25 degrees to direct the underbody airflow smoothly towards the rear of the vehicle.
- Rectifier fin adopted by the rear bumper lower section and the vehicle underbody smoothes flow of air under the body.
[FIN HILITES APPEAR ON CLICK]
- Aero-stabilizing fins on rear combination lights help straight-line and cornering stability.
- Spats in front of the rear tire help enhance aerodynamics by reducing the airflow hitting the tire.
- A bead is used for the rear fender liner, which effectively directs airflow generated by tire rotation to the outside, helping to enhance aerodynamics.
- By giving the trunk rear edge a sharp line, airflow from the roof flows smoothly rearward.
- Rear spoiler on F SPORT forces the air vortex to the back of the vehicle, thereby reducing drag.

WHEELS

- altering the wheel surface reduced the Cd value.

Double-Wishbone Front Suspension



LEXUS

FRONT SUSPENSION

- Forged aluminum-alloy upper and lower arm, and aluminum-alloy steering knuckle, for weight reduction and higher rigidity.
- New high-mount upper-arm double-wishbone suspension for optimized suspension geometry.
- Lower bushing spring rate has been increased by approximately 40%.
- Monotube-type shock absorber for consistent damping force.
- Stabilizer bar spring rate and arm ratio increased.
- Rebound spring rate increased.
- Upgrading the oil, oil seal and valve (AVS-equipped car) contributes to smooth sliding and damping.
- Revised center point for enhanced anti-lift and anti-squat control.
- To help enhance road-surface tracking and ride quality, damping force has been revised:
 - Generating damping force from extremely low vehicle speed helps realize linear vehicle response to steering inputs.
 - Revised damping force helps suppress unnecessary movements in sprung mass.



REAR SUSPENSION ARMS

- Forged aluminum-alloy upper arm for weight reduction and higher rigidity.
- Forged aluminum-alloy toe-control arm for weight reduction and higher rigidity.

[ON CLICK CIRCLE SPRING]

- Spring and shock absorber are now separate for improved geometry.
- High-tensile steel control links for weight reduction.
- Cover is attached to the lower arm for improved aerodynamics.

SHOCK ABSORBERS

- Monotube-type shock absorber for consistent damping force.
- Upgrading the oil, oil seal and valve (AVS-equipped car) contributes to smooth sliding and damping characteristics.
- To help enhance road-surface tracking and ride quality, damping force has been revised:
 - Generating damping force from extremely low vehicle speed helps realize linear vehicle response to steering inputs.
 - Revised damping force helps suppress unnecessary movements in sprung mass.
- Revised center point for enhanced anti-lift and anti-squat control.

Adaptive Variable Suspension (AVS)

Conventional Control Systems

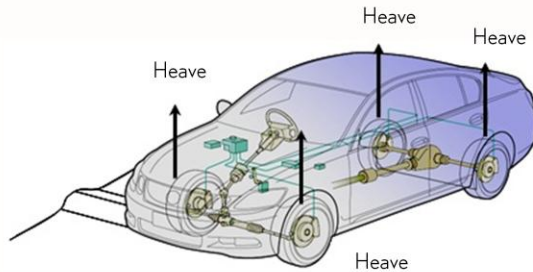

ADAPTIVE VARIABLE SUSPENSION OPERATION

- AVS part of Luxury & F SPORT packages
- now interacts with the Vehicle Dynamics Integrated Management system.
- AVS controls damping force based on road surface conditions and driving operations to help improve ride and stability:
 - When driving on a rough road surface, AVS switches to a lower damping force to help absorb vibrations.
 - When the vehicle pitches, damping force is higher to help assure ride composure.
 - During cornering, damping force is higher for improved handling and stability.
- Drive Mode selector allows the driver to choose between two types of damping modes:
 - In NORMAL, ECO and SPORT S modes, damping control balances ride comfort with handling stability.
 - In SPORT S+ mode, a higher damping force is applied over SPORT S mode.

[ON CLICK NEW CONTROL SYSTEM SHOWS]

Adaptive Variable Suspension (AVS)

Conventional Control Systems

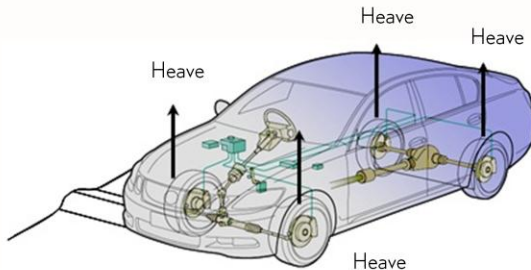

New Control Systems

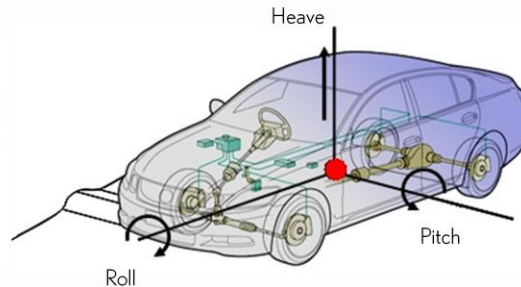

Comparison of New and Conventional Control Systems



ADAPTIVE VARIABLE SUSPENSION (AVS)

4-WHEEL COORDINATED CONTROL

- The new system controls all four wheels simultaneously in a linked manner.
- This enables oscillation control, not only in the heave direction, but also in the directions of roll and pitch.

VEHICLE SPEED-SENSING CONTROL

- Controlling damping force in accordance with vehicle speed helps to achieve both ride comfort at low speed and handling stability at high speed.

ANTI-DIVE CONTROL

- Predicts a vehicle's diving motion from the brake pedal operation and sets a higher damping force to help reduce the body's dive speed.

ANTI-SQUAT CONTROL

- Reduces the amount of vehicle attitude change when accelerating, helping to achieve excellent ride comfort and handling stability.

RUGGEDNESS-SENSING CONTROL

- Reduces the damping force when rough vibration is sensed based on vertical G sensor output while driving over irregular road surfaces.

UNSPRUNG MASS VIBRATION DAMPING CONTROL

- Gives a higher damping force when unsprung resonance is detected based on speed sensor signal output.

PRE-COLLISION SYSTEM COOPERATIVE CONTROL

- When the driving support computer senses a possible collision, increased damping force is used to help reduce brake dive.

VEHICLE STABILITY CONTROL COOPERATIVE CONTROL

- Applies the appropriate damping force in response to vehicle side skid and friction changes in the road surface to enhance the VSC operation.

Adaptive Variable Suspension (AVS)

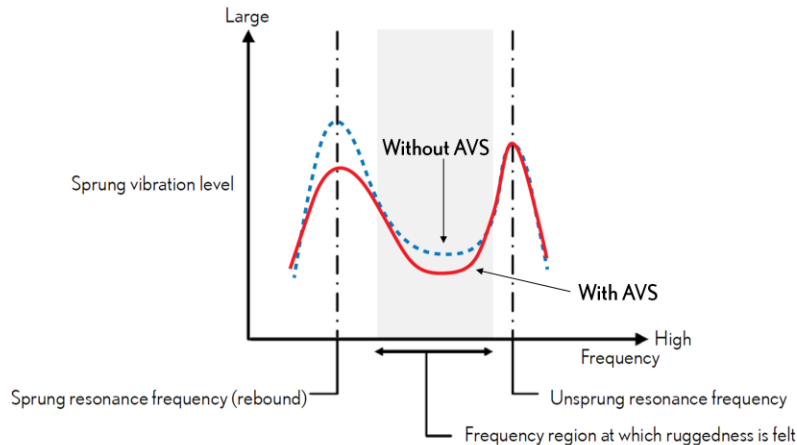

Comparison of AVS Control With and Without



ADAPTIVE VARIABLE SUSPENSION (AVS)

- Controls damping force on all four wheels in response to driver operations and road surface conditions.
- Helps to achieve high measures of ride comfort and handling stability.
- Improvements in rebound control and roll attitude control have been made.

DIFFERENCES FROM THE CONVENTIONAL CONTROL SYSTEM

- With conventional control systems the four wheels are treated independently and vehicle behavior in the direction of heave was controlled at each of the wheel positions.
- The new system controls oscillation behavior at all four wheels simultaneously in a linked manner.
- This enables oscillation control not only in the heave direction, but also in the directions of roll and pitch.

REBOUND CONTROL

- Based on signals from a vertical G sensor, oscillations are detected in the directions of heave, roll and pitch due to inputs from the road surface.
- By controlling damping force on all four wheels with non-linear H -infinity control logic to suppress oscillations in three directions, rebound is naturally smoothed out, helping assure excellent ride comfort.

Adaptive Variable Suspension (AVS)

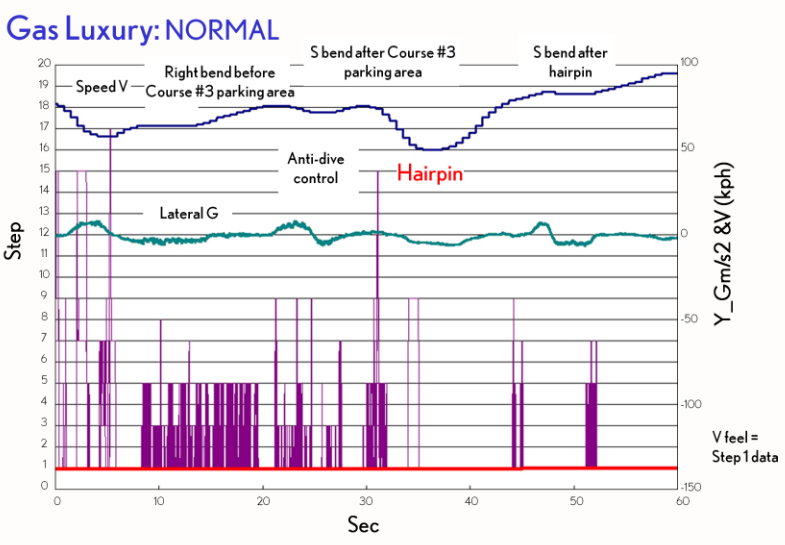

As an actual example, this chart shows the frequency of AVS control operation when driving on the circuit at Higashifuji.

Adaptive Variable Suspension (AVS)

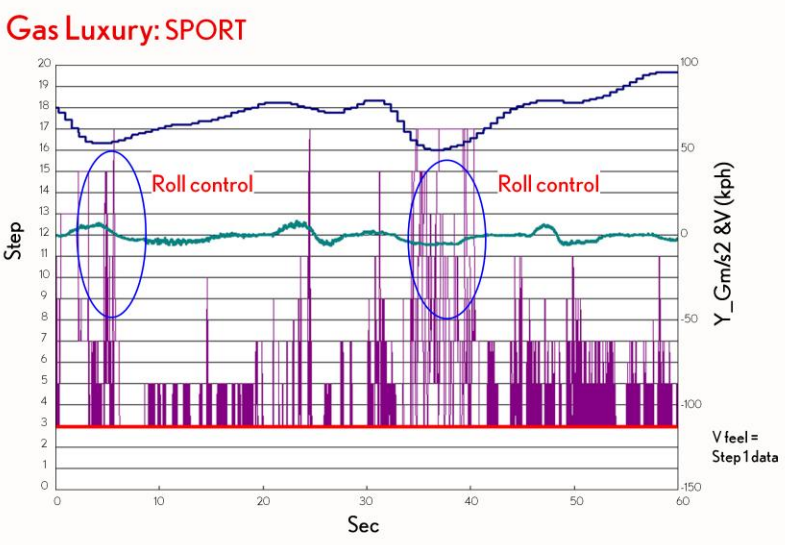

In SPORT Mode, there is a lot of roll control, applying the necessary damping force to enable highly confident cornering.

This chart shows actual control in real time.

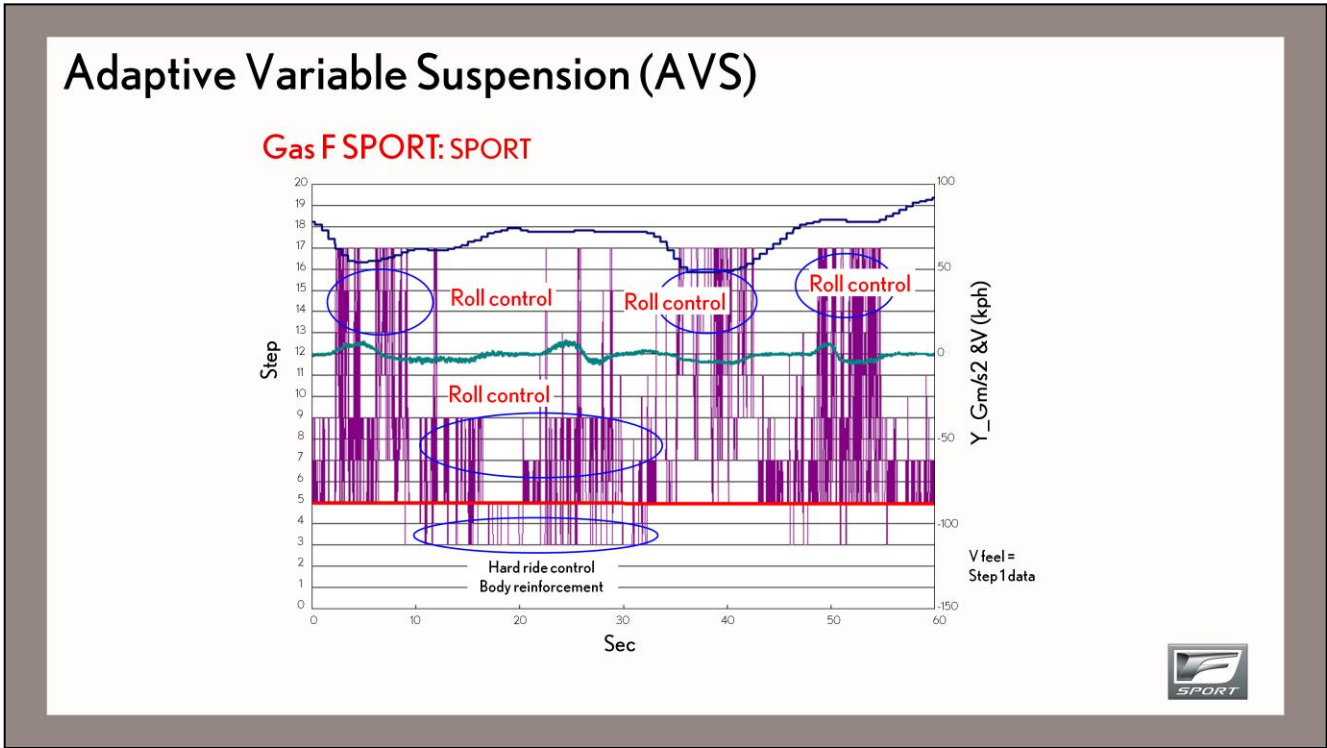

The vertical axis shows the number of steps—the higher the value, the greater the damping effect.

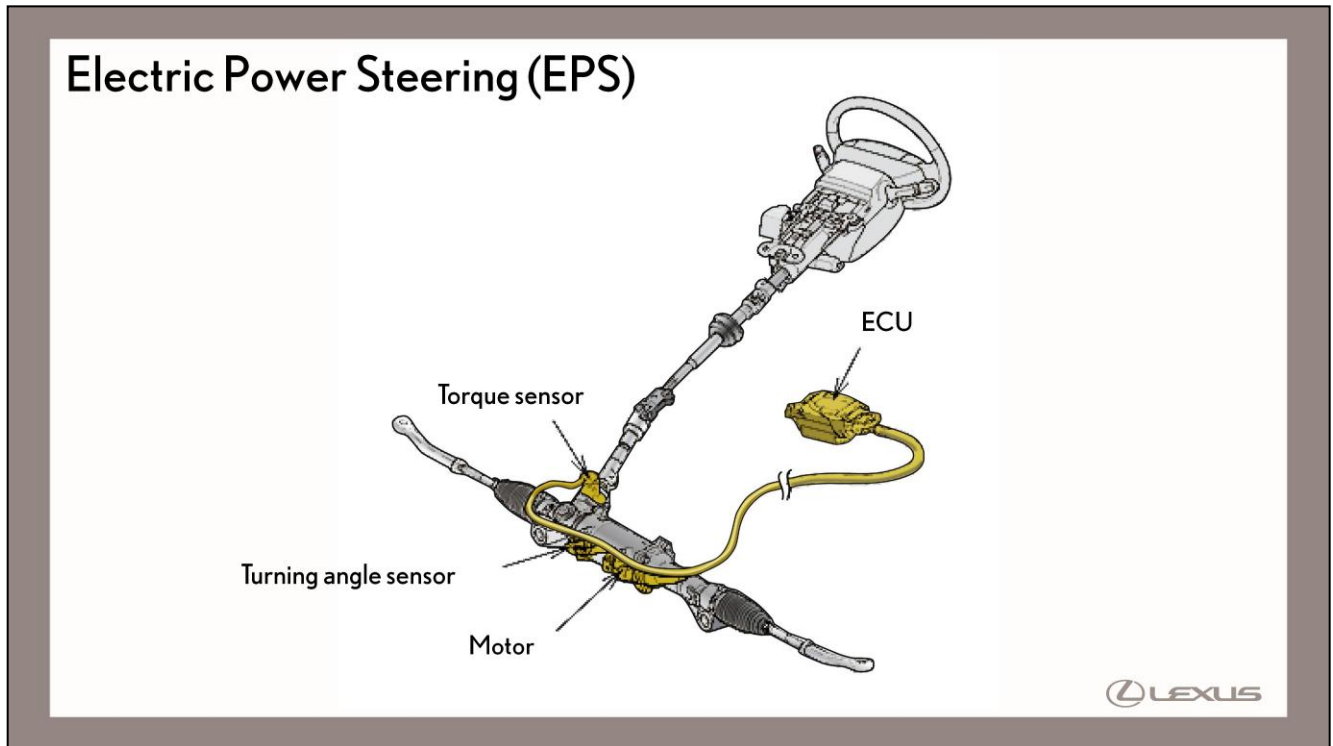

RACK ASSIST ELECTRIC POWER STEERING (EPS) SYSTEM

- EPS uses an electric motor and reduction gear mounted to the steering gear housing to reduce the effort required for steering.
- Through cooperative control when SPORT S+ mode is selected, EPS helps give more direct handling.
- Steering gear ratio has been changed and EPS assist has been optimized to help enhance steering responsiveness.

CHANGES IN MECHANICAL PARTS

- Lateral rigidity of the mounting bushing has been increased and internal gear friction has been revised.

CHANGES IN THE CONTROL SECTION

- EPS assist characteristics have been optimized to match vehicle characteristics.
- EPS assist characteristics are changed in SPORT S+ mode for more direct handling in response.

Electric Power Steering

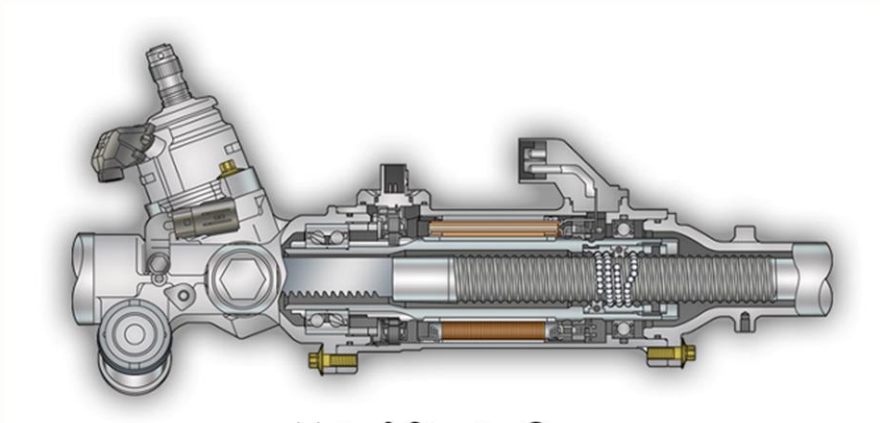

Motor & Steering Gear



RACK ASSIST ELECTRIC POWER STEERING (EPS) SYSTEM

- Voltage varies in response to the amount of steering boost needed and VDIM demand.



A DIFFERENT DIMENSION OF DRIVING

Lexus Dynamic Handling system (LDH) with Variable Gear Ratio Steering (VGRS) for the front and Dynamic Rear Steering (DRS) for the rear is available:

- In the region of regular use, the steering angles of the front wheels and rear wheels are under active control, helping to realize the ideal vehicle responsiveness to both cornering and lateral shift.
- At the limit, active control of steering angle is integrated with braking control to help achieve the ultimate in kinematics.

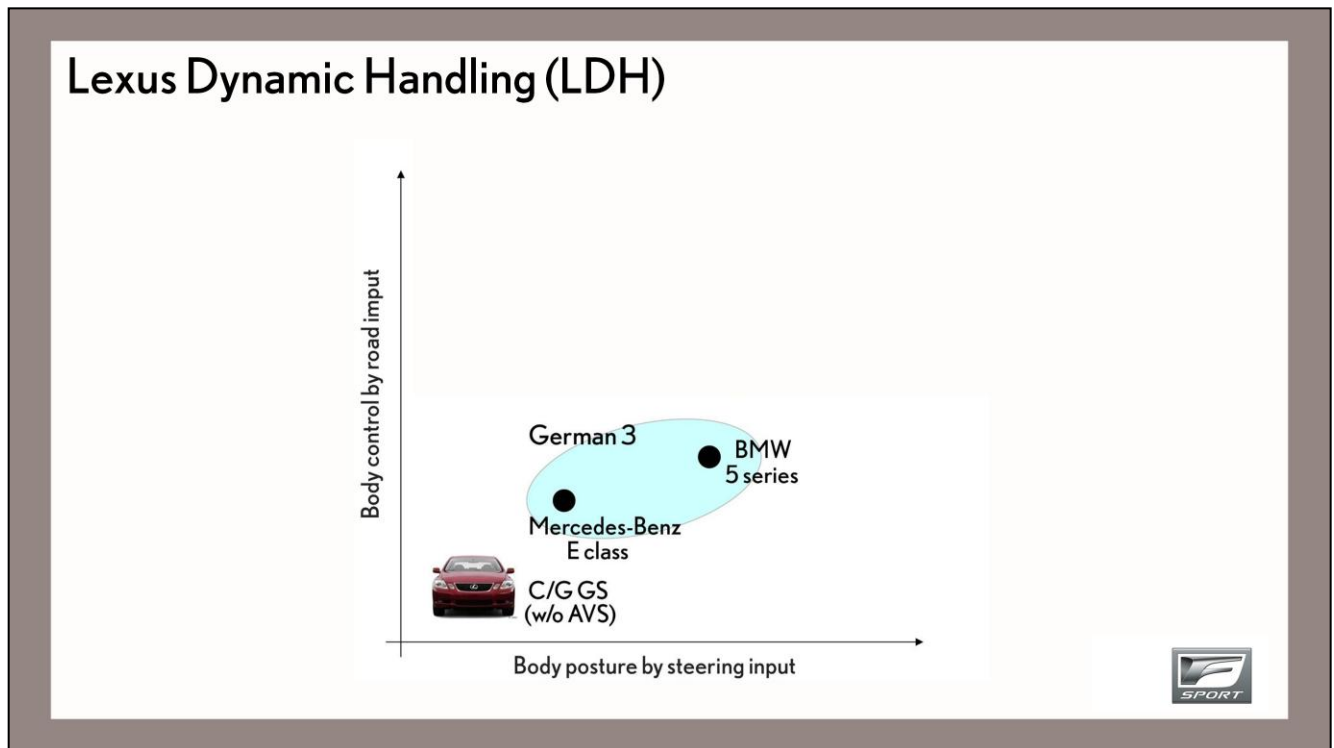

LEXUS DYNAMIC HANDLING (LDH)

- LDH is a new system for Lexus that results in stable vehicle behavior.
- LDH is available on the F SPORT for the ultimate in dynamic performance.
- World's first combination of a dynamic handling system and a hybrid drive.
- LDH adds Dynamic Rear Steering (DRS) for controlling the rear-wheel steering angle to the conventional Variable Gear Ratio Steering (VGRS) system controlling the front-wheel steering angle.
- Combined with Electric Power Steering (EPS) to control steering torque, the system assures vehicle responsiveness and stability in line with driver expectations.
- By controlling the VGRS output angle and DRS output angle in accordance with the driver's steering operations and vehicle speed, LDH helps achieve excellent vehicle response characteristics.
- The direction and magnitude of the VGRS and DRS output angles are computed from the objective vehicle characteristics set according to vehicle speed and a vehicle dynamics model.
- The objective vehicle characteristics are set as follows according to the vehicle speed range:
 - Low-speed range objective: Enhanced maneuverability
 - Medium-speed range objective: Enhanced steering responsiveness
 - High-speed range objective: Enhanced peace of mind and comfort

Lexus Dynamic Handling (LDH)

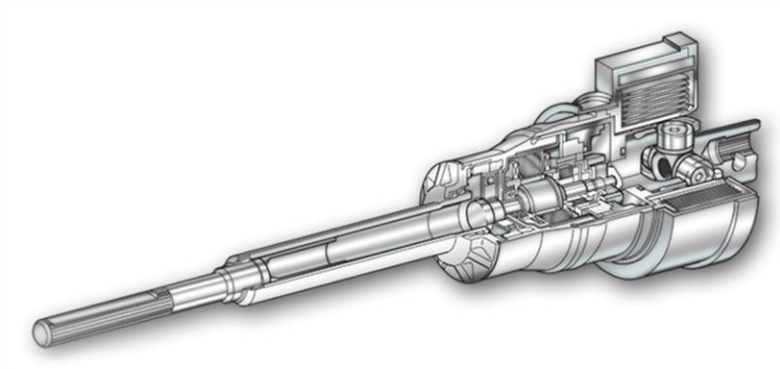

Variable Gear Ratio Steering (VGRS)



VGRS CHARACTERISTICS

- VGRS controls steering angle in accordance with vehicle speed and driver steering input.
- VGRS automatically changes the steering gear ratio in accordance with vehicle speed and driving conditions:
 - VGRS decreases the number of turns during extremely low vehicle speed or when performing a U-turn.
 - Optimum gear ratio is chosen when traveling at low to mid vehicle speeds for light, easy-to-handle vehicle responsiveness.
 - When traveling at high speed, VGRS helps improve vehicle responsiveness with a controlled and stable feel.

VGRS DAMPER

- Rubber damper between the VGRS motor and steering wheel helps reduce vibration and improve feel.

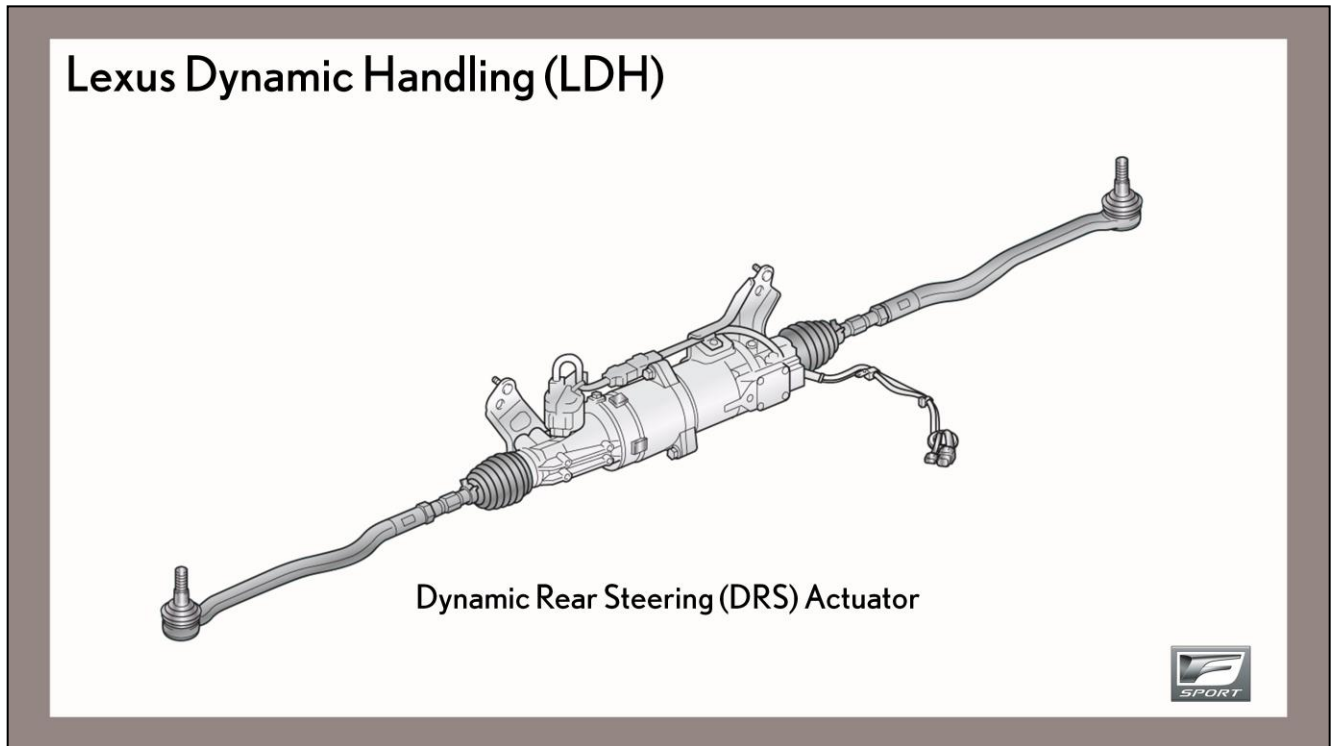

DYNAMIC REAR STEERING (DRS) ACTUATOR

- Improves transitional response, as in changing lanes.
- The DRS actuator is a compact structure comprised of a brushless DC motor, reduction gear and trapezoidal screw laid out coaxially with the tie-rods, joined to the rear suspension's toe control arms.
- The DRS actuator operates in the following way to steer the rear wheels:
 1. Motor torque goes through gear reduction at the rotor end and the rotation of the carrier is transferred to the trapezoidal screw.
 2. Trapezoidal screw, converts rotational motion to linear motion, which steers the rear wheels.
- The rear wheel steering angle is set to 0-2 degrees in both directions.

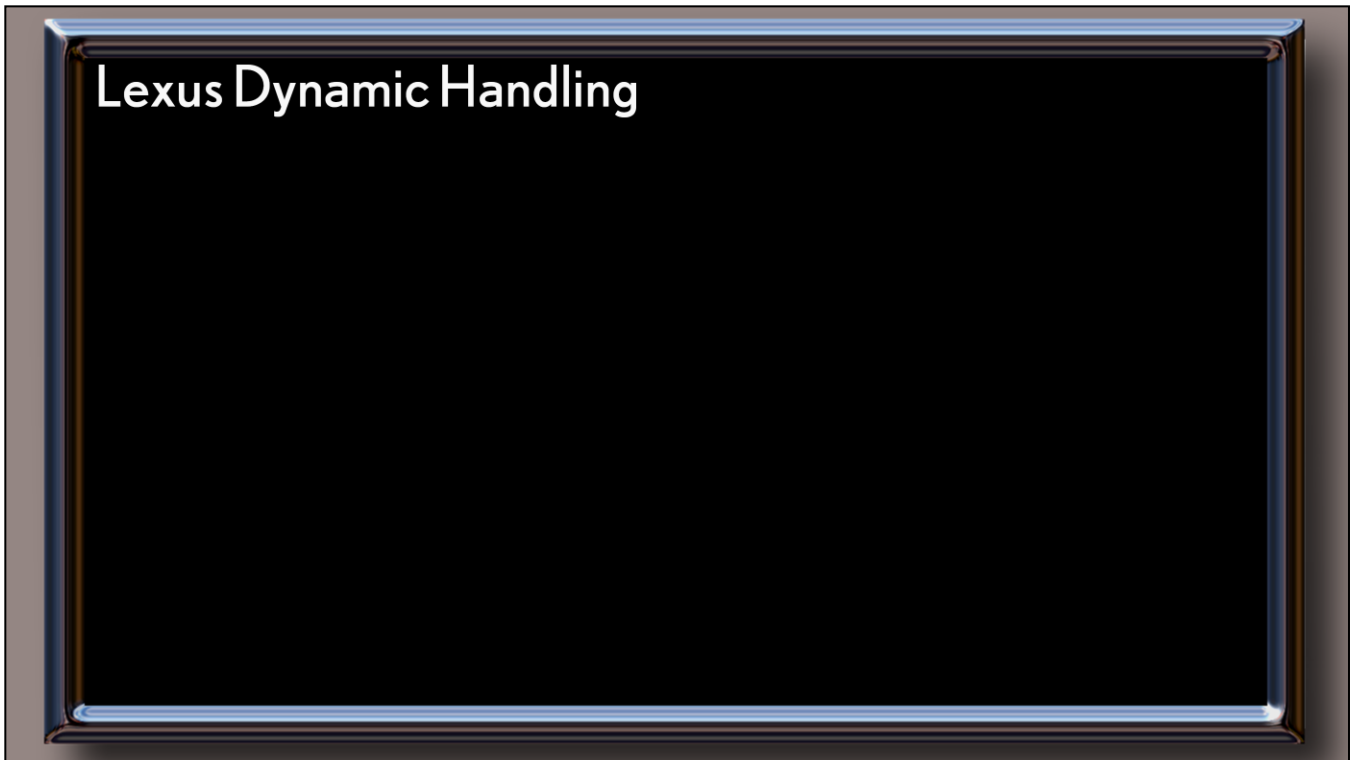

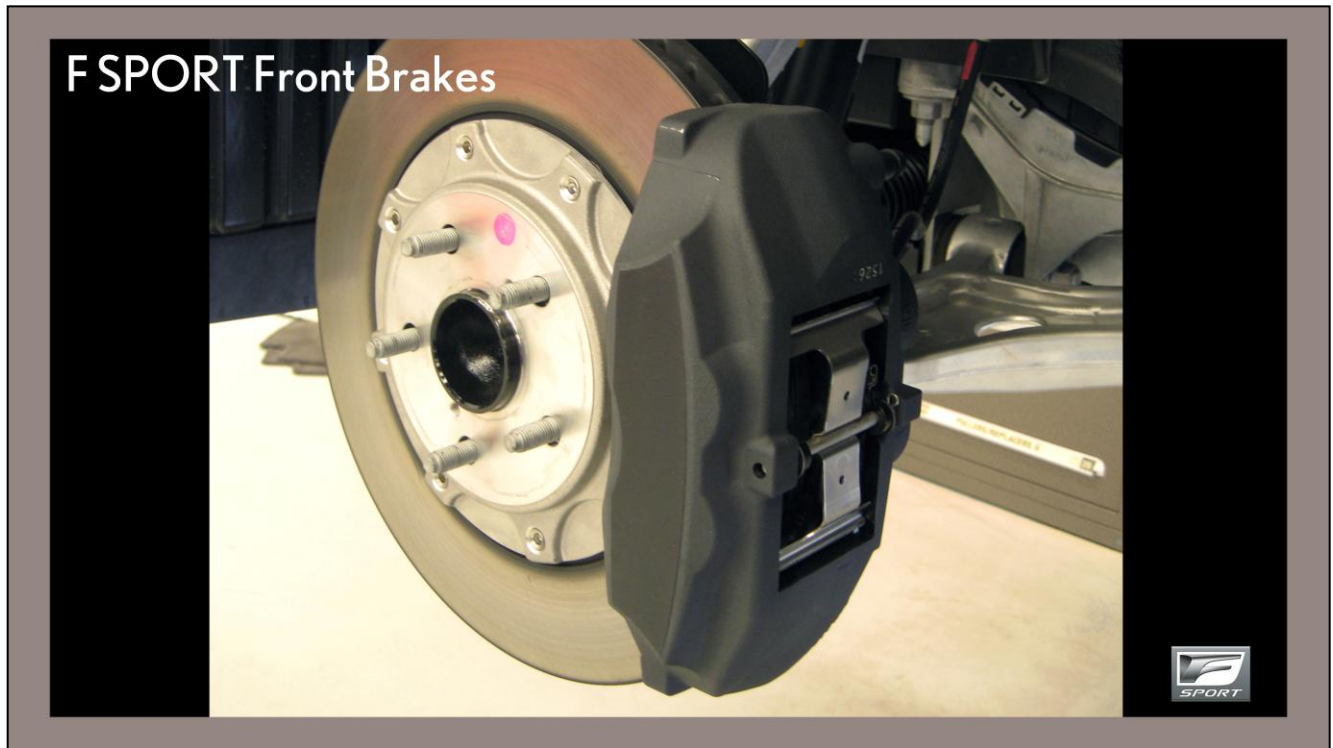

F SPORT FRONT BRAKES FOR 2WD

- Swept area is 8.15 square inches (vs. 6.18 square inches with standard front brakes).
- Pad shape helps reduce vibration and brake noise.
- Caliper shape is designed to project a high-performance image.

F SPORT Front Brakes

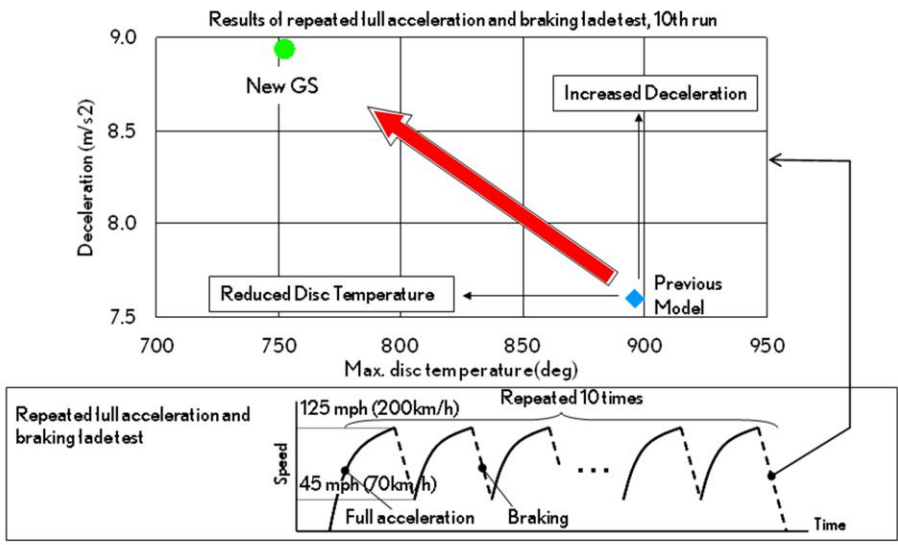

BRAKE FADE PERFORMANCE

- Brake fade performance has been improved with F SPORT front brakes.

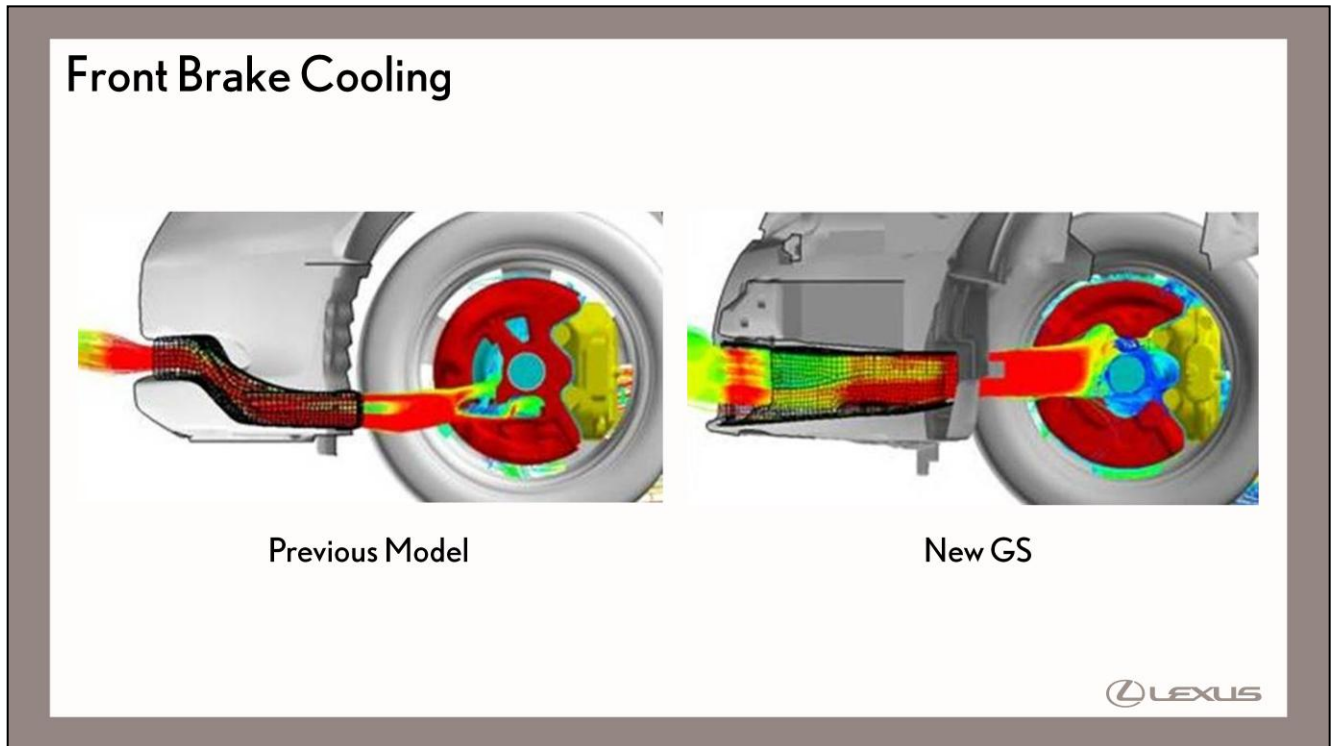

FRONT BRAKES

- Front brake cooling performance increased by enlarging the opening in the bumper with a more direct path.

REAR BRAKES

- Add larger 17-inch disc brakes.
- Add aluminum calipers for reduced weight.
- Increased rotor thickness for improved anti-fade performance.
- Revised pad material with more stable braking effectiveness.

BRAKE PEDAL

- Pedal ratio has been optimized for excellent pedal feedback.
- Pedal pad angle and shape has been optimized.



[WHEELS APPEAR SEPARATELY ON CLICK]

17-INCH ALLOY WHEELS

- 9-spoke design with elongated spoke shape.

18-INCH ALLOY WHEELS (LUXURY, OPTIONAL ON GS 350)

- 10-spoke design with a sharp detail (GS 350 option).
- Nine paired spokes come together at the wheel center (Luxury).

19-INCH ALLOY WHEELS (F SPORT)

- Differential widths: 8" ft, 9" rr.
- 265 mm rear tire is widest of any Lexus sedan

TIRES

- Reduced rolling resistance contributes to improved fuel economy.
- P225/50R17 tires on 350 GS emphasize excellent performance.
- P235/45R18 tires emphasizes a balance of each performance attribute.
- P235/40R19 and 265/35R19 tires emphasize handling stability and help assure high kinematic performance.



DRIVE MODE SELECT

The transmission incorporates many features adopted from the Lexus IS F high-performance sedan, including faster shifts, earlier torque converter lockup and downshift throttle blips.

SYSTEMS CHANGED IN EACH MODE

- ECO Mode:
 - Slower throttle mapping
 - Air conditioning
- SPORT S Mode:
 - Performance throttle mapping
 - Faster transmission shifts and increased responsiveness
 - Faster torque converter lockup
 - Downshift throttle blips
- SPORT S+ Mode:
 - Sport suspension settings
 - Sport Electric Power Steering and Variable Gear Ratio Steering settings
 - Revised VDIM settings

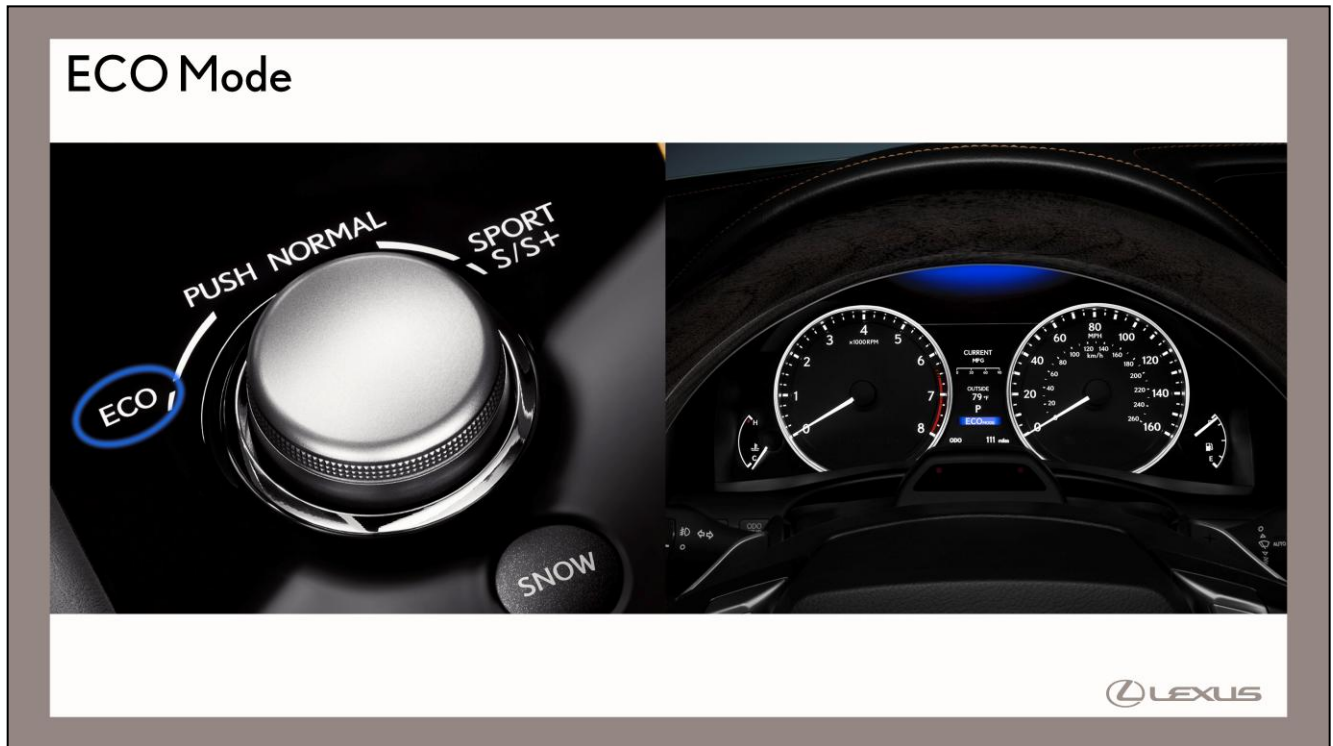

ECO MODE OPERATING METHOD AND METER DISPLAY

- In ECO Mode, the powertrain is controlled according to fuel-saving parameters:
 - Engine power output, throttle mapping and air conditioning are controlled to enable driving that prioritizes fuel economy.
 - When ECO Mode is selected, the air conditioner is controlled in cooperation with the seat heaters, helping to achieve both fuel economy and immediate heating effect.

OPERATING METHOD

- ECO Mode can be selected by turning the dial of the drive mode selector switch counter-clockwise.
- To cancel, press the drive mode selector switch or turn the dial counter-clockwise again.

METER DISPLAY

- When ECO Mode is selected, the “ECO Mode” indicator in the meter is illuminated.
- When ECO Mode is selected, the meter’s upper display is blue;
- Intensity of blue light depends on how economically the vehicle is driven.

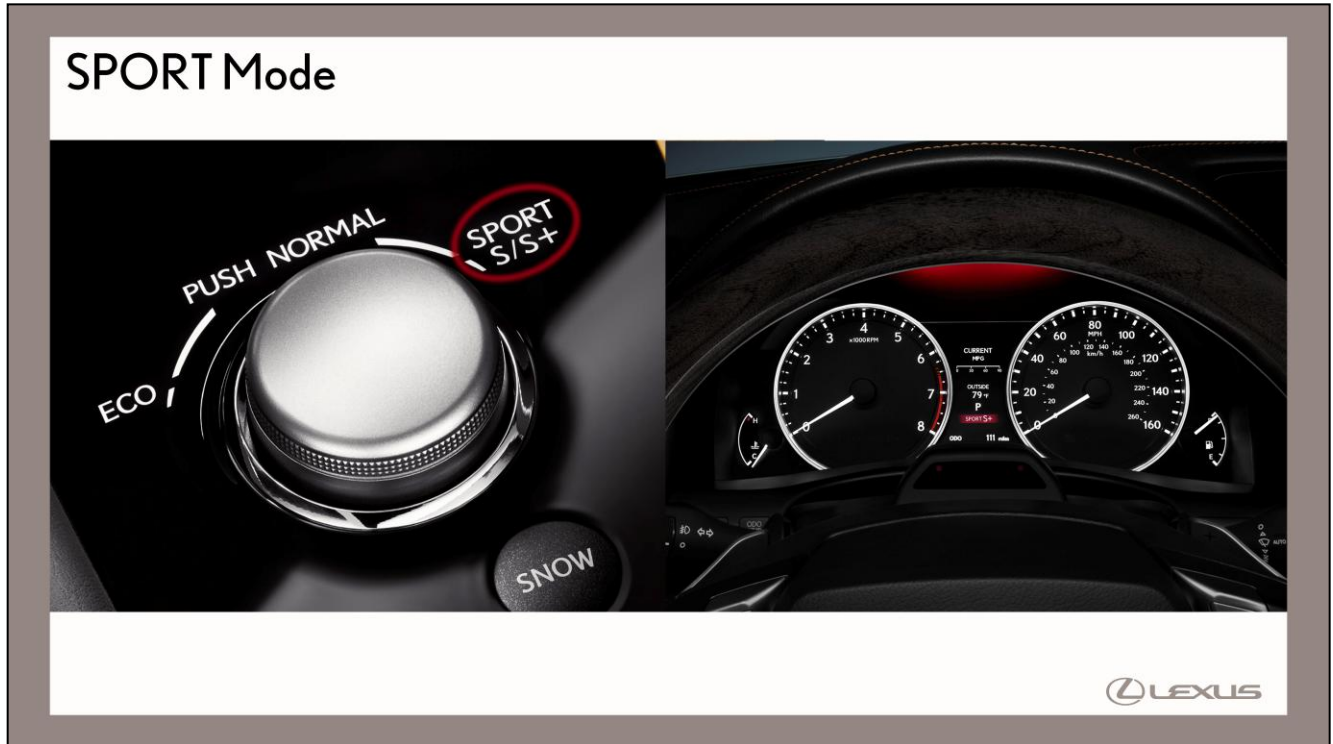

SPORT MODE OPERATING METHOD AND METER DISPLAY

- In SPORT Mode, the powertrain is controlled according to performance parameters:
 - Gasoline engine model: Shift timing is changed, helping to improve acceleration responsiveness.
 - Hybrid model: Drive force in the partial throttle range and engine speed responsiveness at full throttle are enhanced, helping to improve acceleration responsiveness.

OPERATION METHOD

- The SPORT Mode (SPORT S Mode on AVS-equipped model) can be selected by turning the dial of the drive mode selector switch clockwise.
- With the AVS-equipped model, a further turn to the right selects SPORT S+ Mode.

METER DISPLAY

- When SPORT Mode is selected, the "SPORT Mode" indicator in the meter is illuminated.
- When SPORT Mode is selected, the meter's upper display is red.

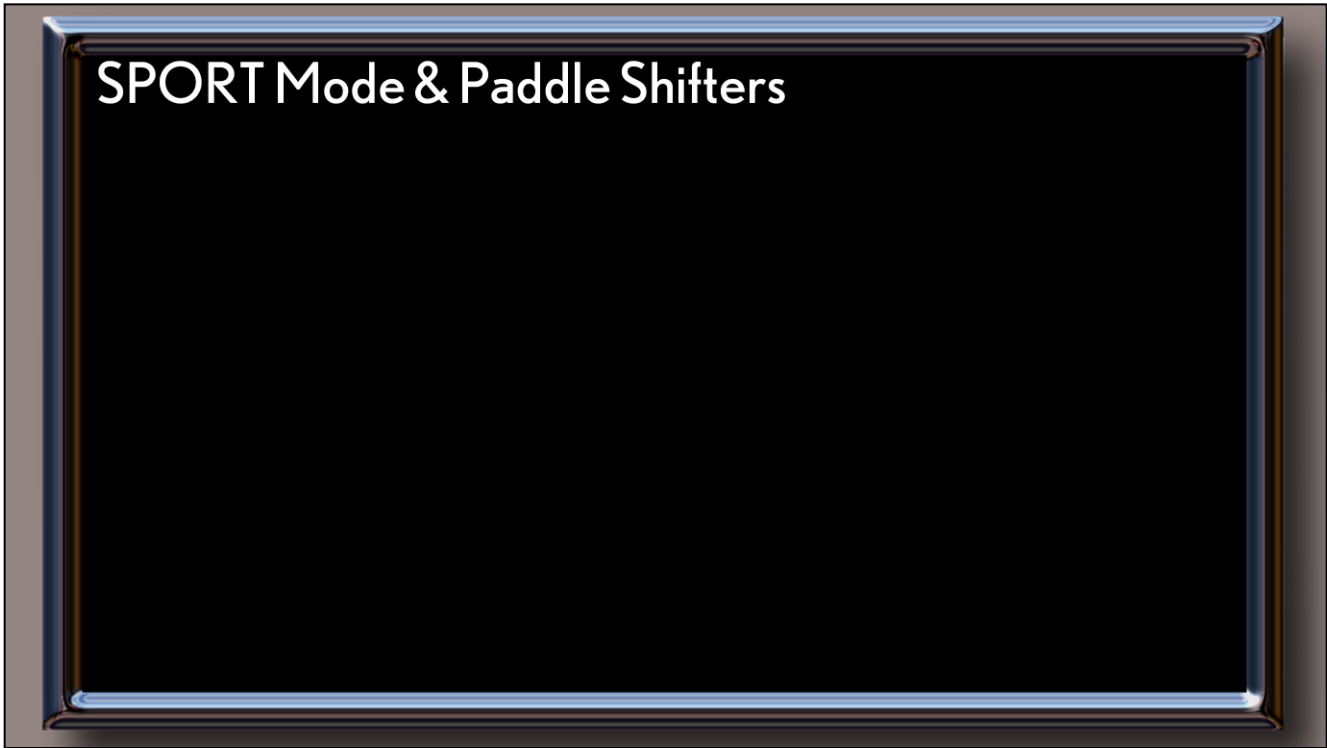

ENGINE SOUND VIDEO

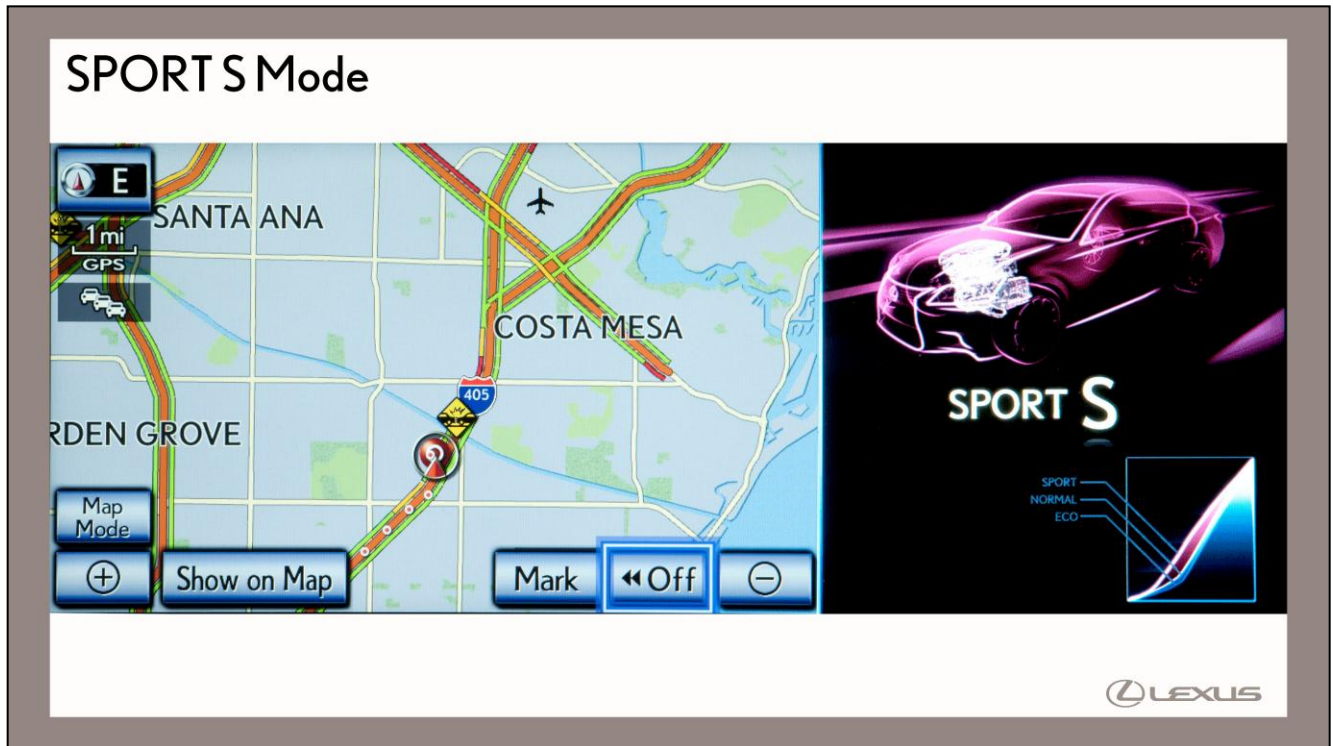

SPORT S MODE OPERATION METHOD AND METER DISPLAY

- SPORT S Mode is available on all models.
- When the driver selects SPORT S Mode, vehicle characteristics are switched to a sportier drive more responsive to steering inputs.
- In SPORT S Mode, the powertrain is controlled according to sport specifications as indicated in the following:
 - Gasoline engine model: Shift timing is changed, helping to improve acceleration responsiveness.
 - Hybrid model: Drive force in the partial throttle range and engine speed responsiveness at full throttle are enhanced, helping to improve acceleration responsiveness.

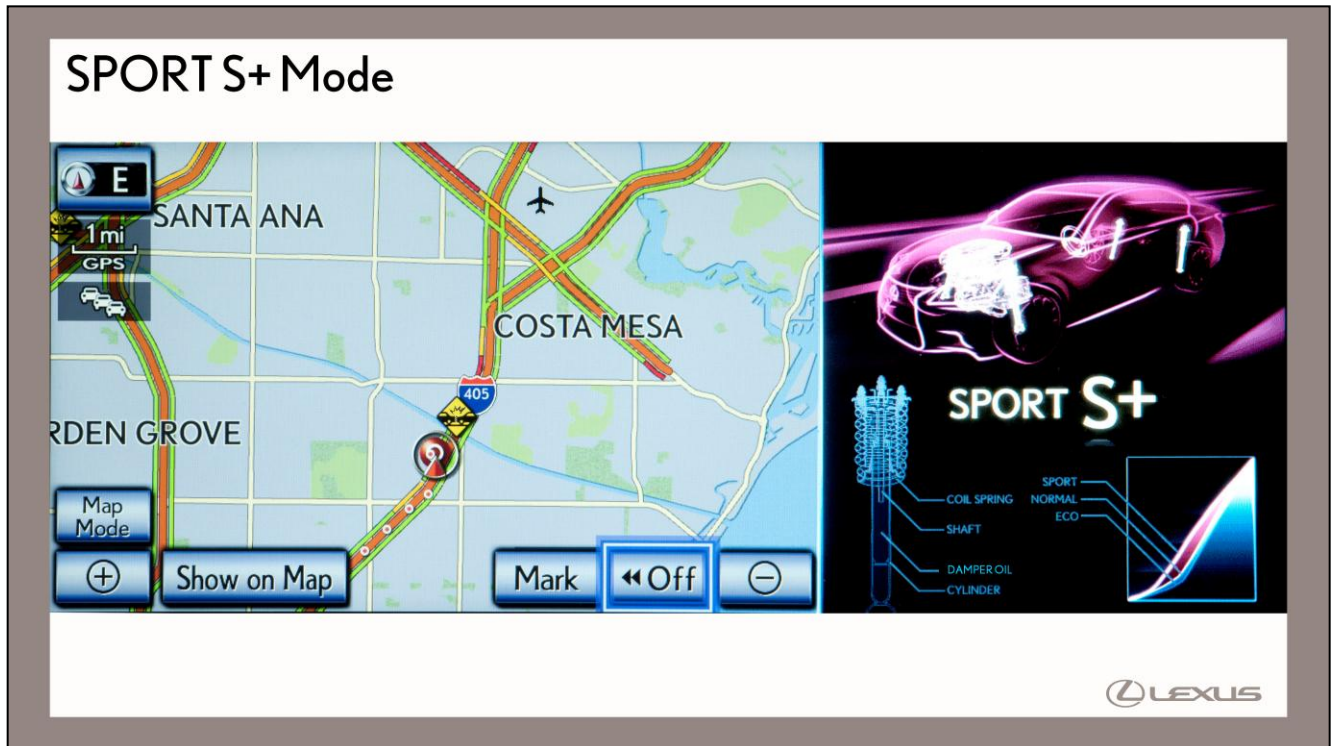

SPORT S+ MODE OPERATION METHOD AND METER DISPLAY

- In SPORT S+ Mode, in addition to drive force control, integrated management of steering control and suspension control are changed as follows to help enhance handling stability and enable more aggressive driving:
 - Adaptive Variable Suspension (AVS): Change to higher damping force compared to NORMAL Mode.
 - Electric Power Steering (EPS): Changes the amount of assist of the power steering.
 - Variable Gear Ratio Steering (VGRS): Changes the gear ratio amplification factor.
 - Dynamic Rear Steering (DRS): Enhances convergence of rear wheel steering angle.
 - Vehicle Dynamics Integrated Management (VDIM): Changes the amount of control intervention.

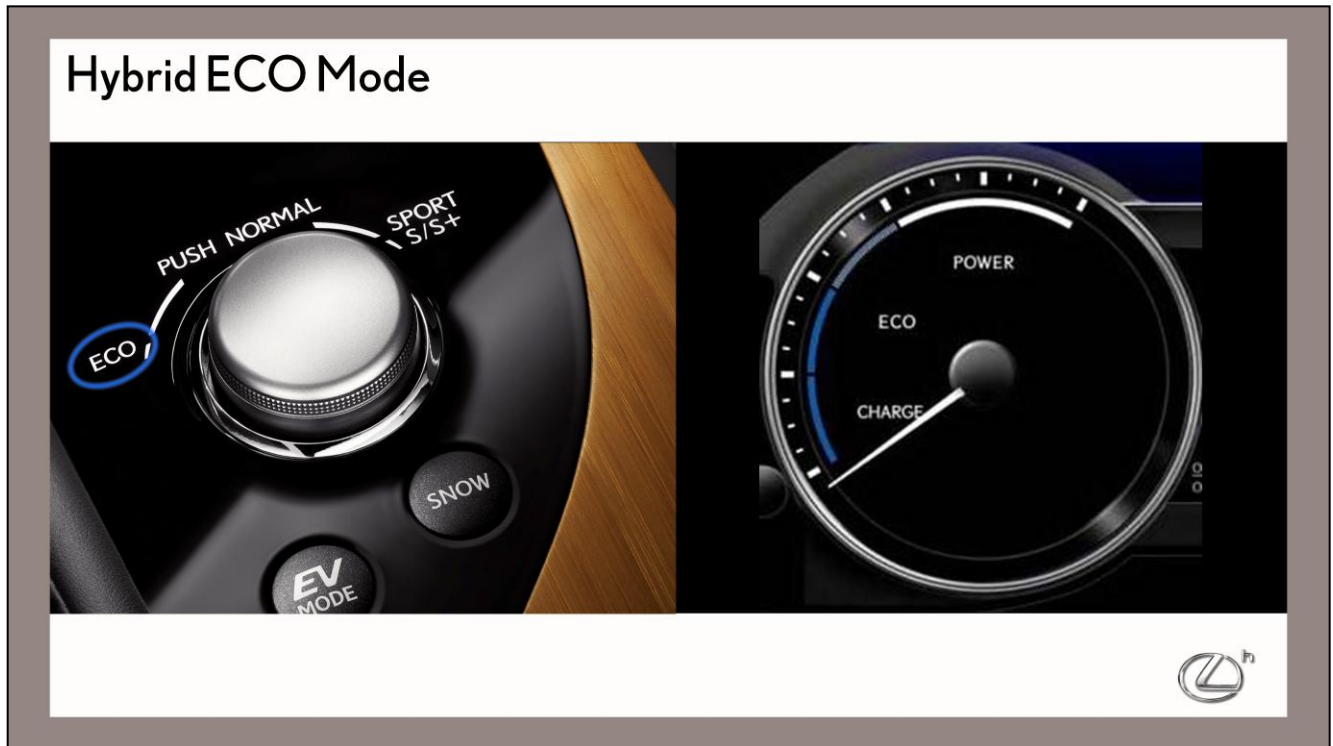

HYBRID SYSTEM INDICATOR AND TACHOMETER DISPLAY SWITCHING

- A customize function enables constant display of either Hybrid System Indicator or tachometer.
- When operating the drive mode select switch, the meter on the left switches depending on the selected drive mode:
 - During normal driving and when ECO Mode is selected, Hybrid System Indicator is displayed.
 - When SPORT S Mode and SPORT S+ Mode are selected, the tachometer is displayed.
 - Hybrid System Indicator is displayed by default.

SYSTEM INDICATOR

The hybrid system power output and regenerative charging are shown in real time by indicators:

- ECO area: Shows that the vehicle is driven in the eco-friendly manner.
- Charge area: Shows regenerative charging.
- Hybrid ECO area: Shows that the vehicle is driven in a condition that promotes frequent electric motor-only operation.
- Power area: Shows that the acceleration exceeds the ECO driving accelerator upper limit.

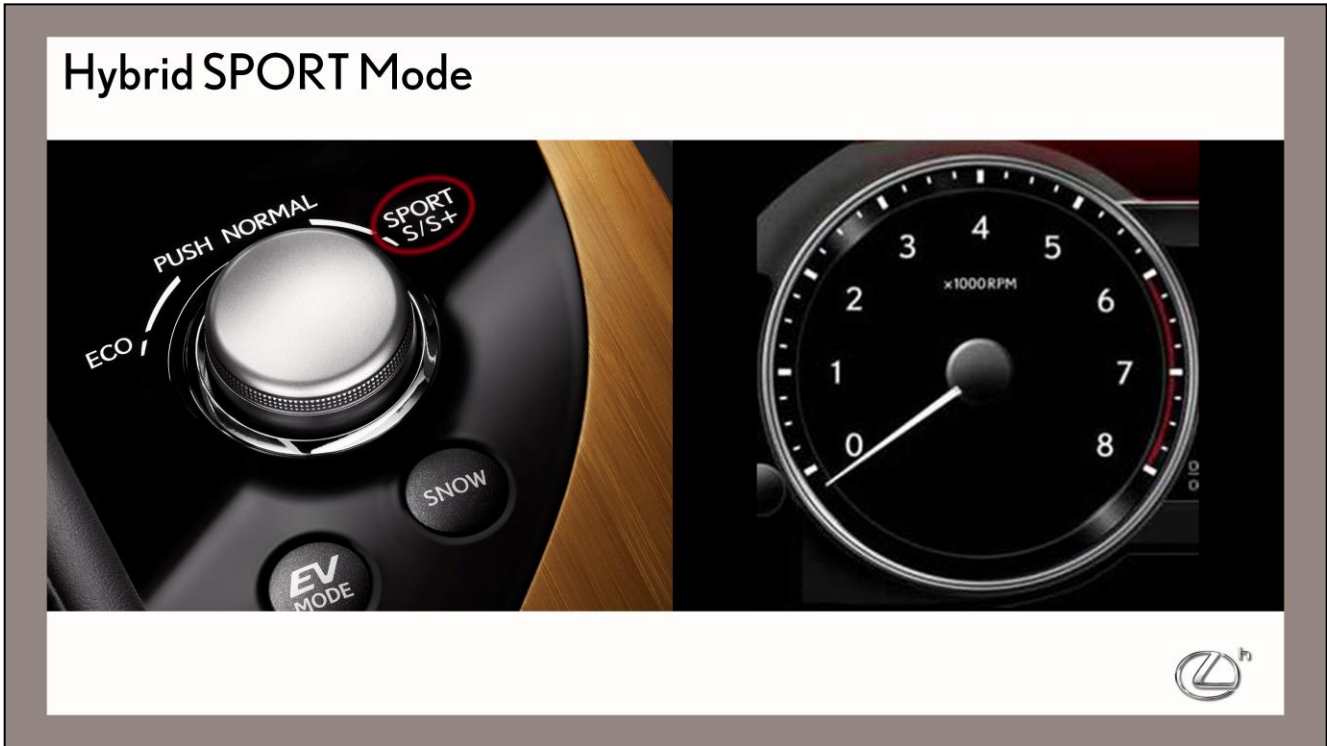

HYBRID SYSTEM INDICATOR AND TACHOMETER DISPLAY SWITCHING

- When SPORT S or SPORT S+ Modes are selected, the tachometer is displayed to show engine speed.

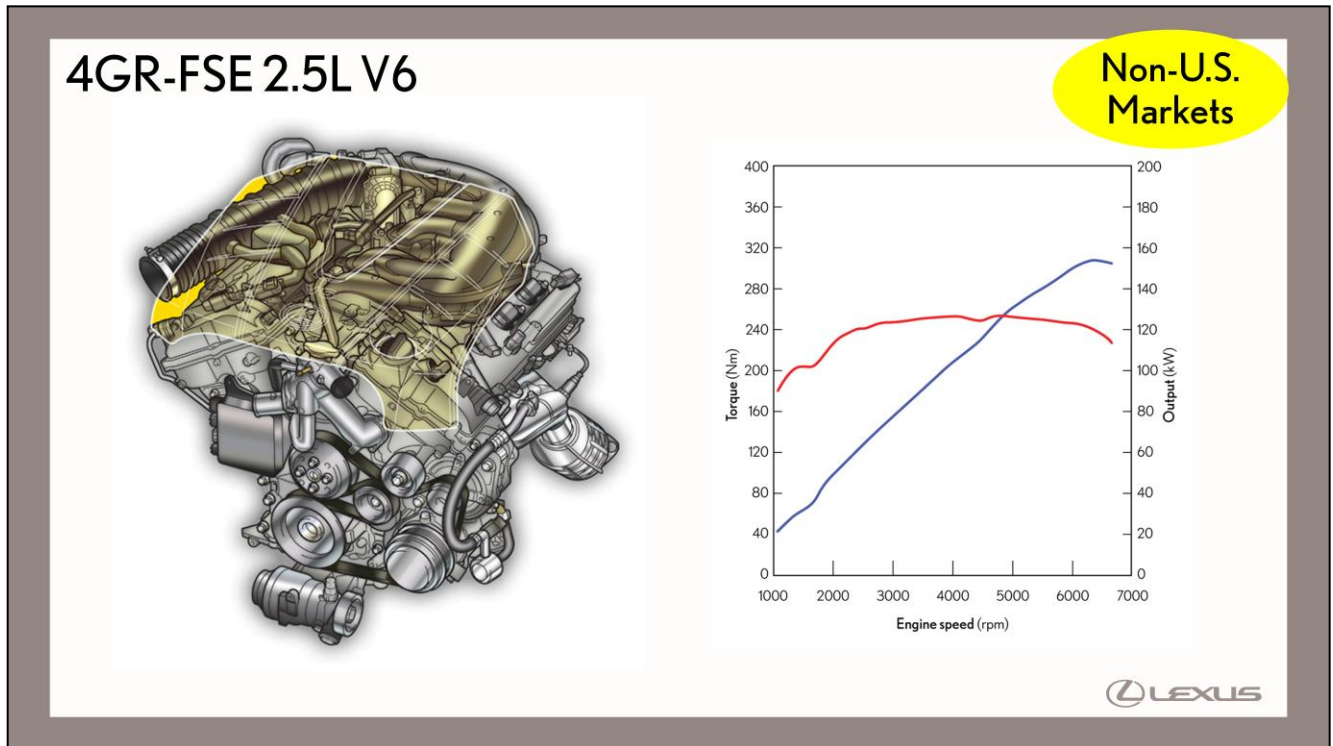

4GR-FSE ENGINE

- 2.5L V6
- 24-valve DOHC with Dual VVT-I & Direct Injection
- 2500 CC: bore X stroke = 83.0 x 77.0 MM
- Compression ratio = 12.0:1
- MAX. OUTPUT = 154 kW @ 6400 rpm
- MAX. TORQUE = 253 NM @ 4800 rpm

CYLINDER HEAD

- Cross-flow layout with independent intake ports and Siamese exhaust ports.
- Vertical intake ports with a notch and edge on the underside of the port outlet, contributing to high intake efficiency with high tumble.
- Small diameter valve stem and valve guides reduce air intake resistance.

EXHAUST MANIFOLD

- Exhaust manifold with integrated thin sheet ceramic catalyst helps enhance engine performance, lower emissions and reduce weight.
- Optimized gas flow reduces exhaust pressure loss to improved output
- Stainless steel improves high-temperature durability and reduces weight.

2GR-FSE 3.5L V6

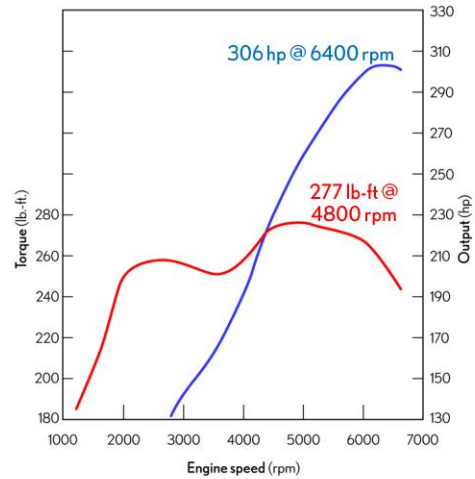
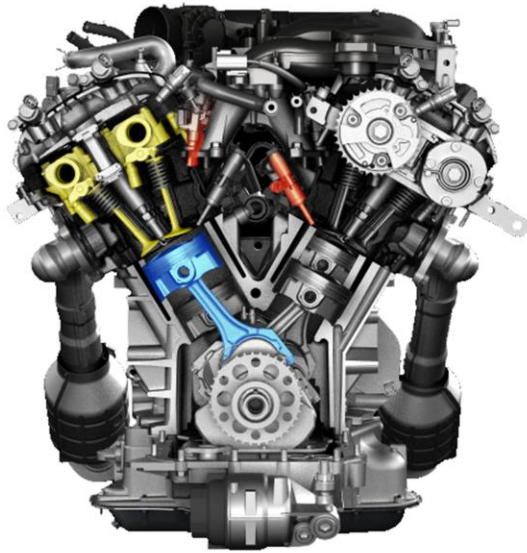

LEXUS

2GR-FSE 3.5L V6 ENGINE

24-valve DOHC with Dual VVT-i

direct with port fuel injection

3456 cc: **bore X stroke** = 94.0 x 83.0 mm

Compression ratio = 11.8:1

MAX. OUTPUT (SAE-NET) = 306 hp @ 6400 rpm

MAX. TORQUE (SAE-NET) = 277 lb-ft @ 4800 rpm

Intake Sound Creator

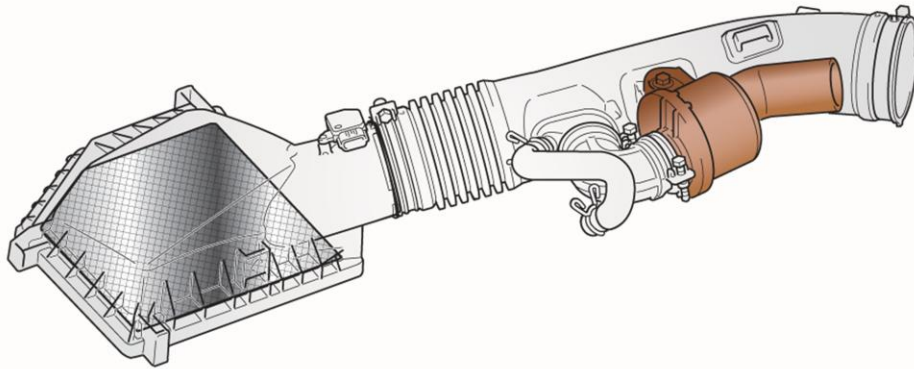

LEXUS

INTAKE SOUND CREATOR

- In developing the new GS, the Lexus team concentrated on sporty engine and exhaust sounds.
- Operates at mid to high rpm.
- A resin damper receives intake pulsations from the air-cleaner hose. The amplitude of the damper induces resonance in pipes fitted upstream and downstream.
- Sound quality has been adjusted in three frequencies according to the pipe resonance frequency and natural vibration frequency of the damper.
- By providing a duct close to the cabin, an exhilarating sound, free of ambient noise, is produced inside the vehicle.

AIR CLEANER

- New filtration material delivers high filtration performance with low pressure loss.
- Carbon filter in the air cleaner cover adsorbs the hydrocarbons that accumulates in the intake system when the engine is stopped in order to reduce evaporative emissions.

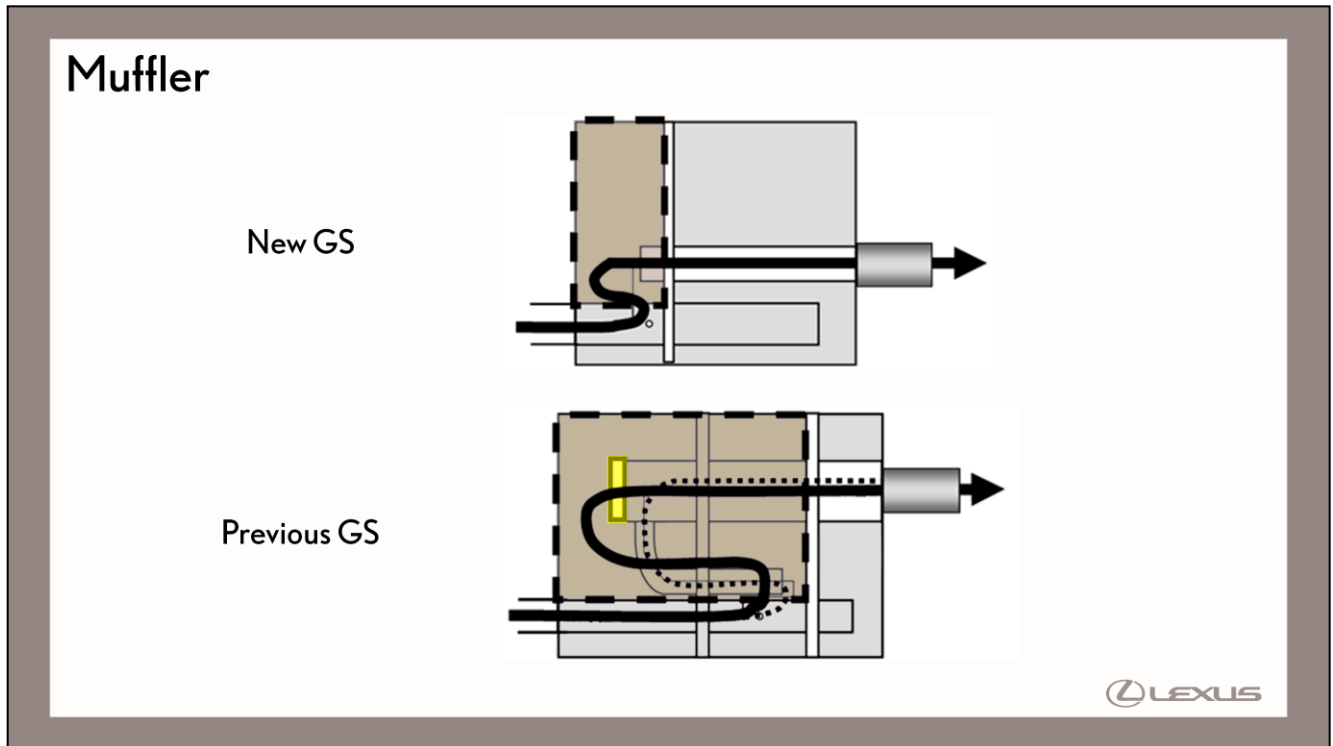

MUFFLER

- Produces a sporty sound at low rpm.
- Previous model used a valve in the outlet tube to help control exhaust sound at low engine speed.
- Adjusting the expansion and resonance chambers inside the muffler gives the new GS a sportier exhaust note.
- This muffler design is only on gasoline models.



6-SPEED SEQUENTIAL SHIFT AUTOMATIC TRANSMISSION

- Standard paddle shifters and sport driving functions.
- Incorporates many features from the Lexus IS F high-performance sedan, including faster shifts, earlier torque converter lockup and downshift throttle blips.

M MODE CONTROL

- The M range (M mode) is located to the side of the gated shift lever's D range.
- When the lever is placed in M mode, the driver can select gears while driving by "+ (UP)" and "- (DOWN)" operations using the shift lever or paddle shifter installed on the steering wheel.
- During M mode, the emphasis is on shift response and feeling.

FIXED GEAR CONTROL

- In M mode, the gear is not changed unless the paddle shifter or shift lever is operated.
- Automatic shifting is conducted in the following cases, even when in M mode:
 - A "-" shift when vehicle speed decreases.
 - When the temperature of automatic transmission fluid and engine coolant drops, shifting is conducted based on a low oil temperature shifting pattern.
 - When the automatic transmission fluid temperature is high, automatic shifting is performed.
 - When the engine speed reaches the redline, gear shifting is conducted automatically.

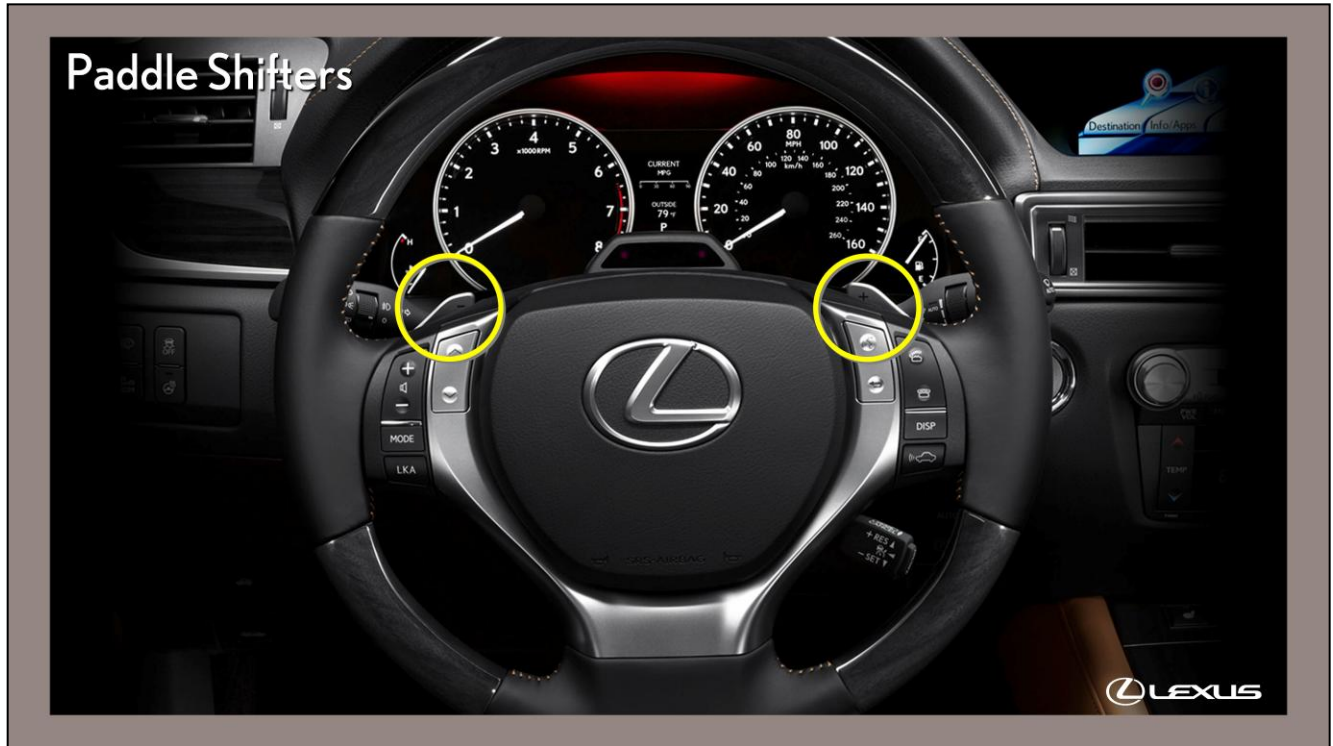

D-RANGE PADDLE SHIFT

- D-range active control makes paddle shifter operations effective in the D range, enabling manual gear shifting.
- Shift ranges can be selected directly by operating the paddle shifter, with no need to shift the lever to the M range.
- This speeds up downshifts during engine braking and when exiting corners.
- In the event of a "+" operation during AI-SHIFT control, AI-SHIFT control is canceled and the system changes to D-range paddle active control.

6-Speed Sequential Shift Automatic Transmission (A760E)

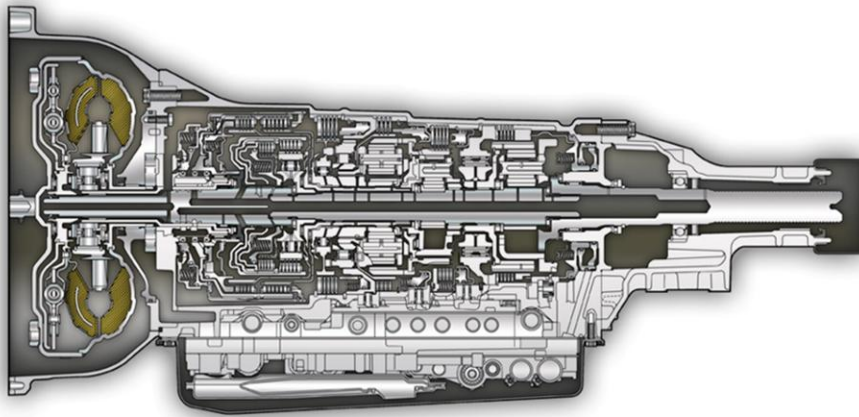

DRIVING RESPONSE AND ACCELERATION MANAGEMENT SYSTEM (DRAMS)

- DRAMS conducts cooperative control of the engine, transmission and associated systems on the drive force axis by exhibiting optimum drive force in response to accelerator pedal operation.
- Since DRAMS obtains drive force that the driver expects in a whole range of driving scenarios, it helps to realize excellent responsiveness and a high-quality driving feel.

AUTOMATIC 2ND GEAR START-STOP SYSTEM FOR LOW-FRICTION ROADS

- When accelerating from a stop on slippery surfaces, the transmission shifts automatically to 2nd gear to help reduce wheel spin.

GEAR CHANGE PROHIBIT CONTROL DURING HIGH-DIFFERENTIAL DRIVING

- Driving on a road surfaces with a different slipping tendency between left and right sides, gear shifting is prohibited to protect the differential.

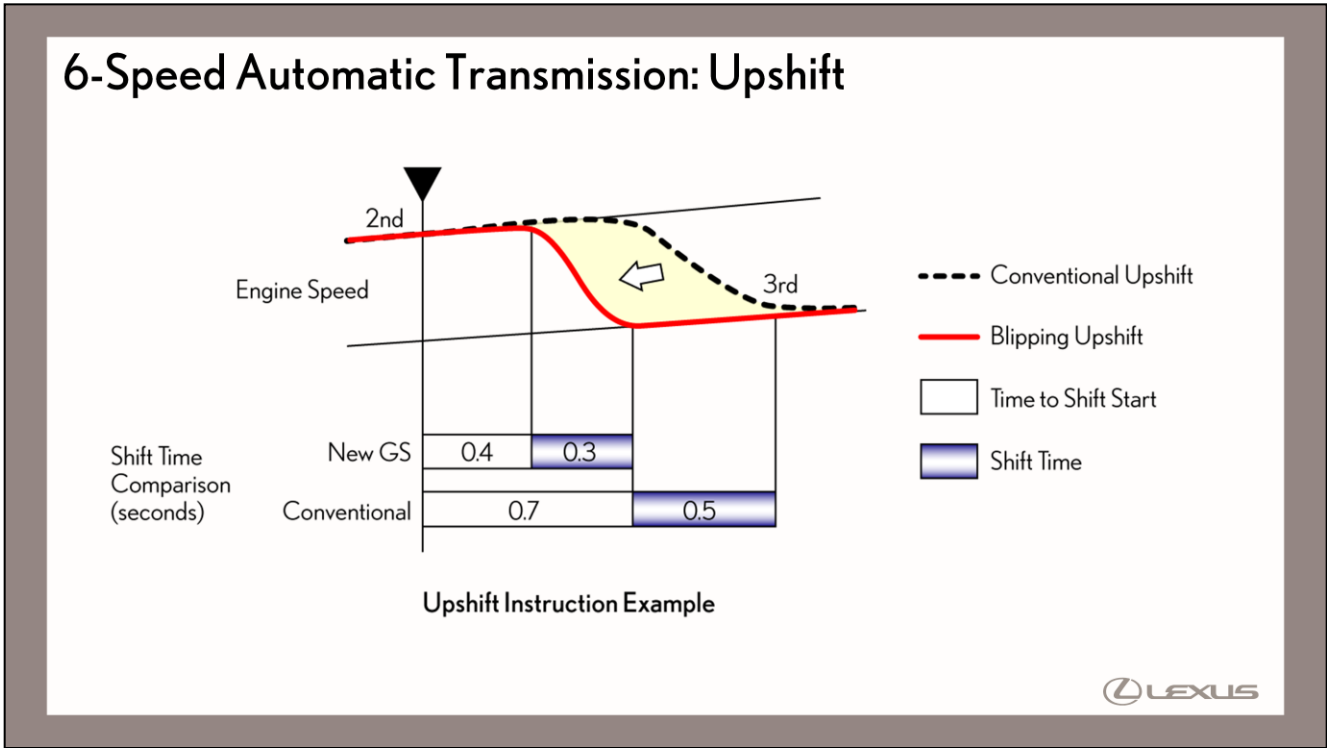

HIGH-RESPONSE UPSHIFT CONTROL

- The hydraulic control system performs quick and precise clutch engage/release control in a little as 0.3 seconds.

6-Speed Automatic Transmission: Downshift

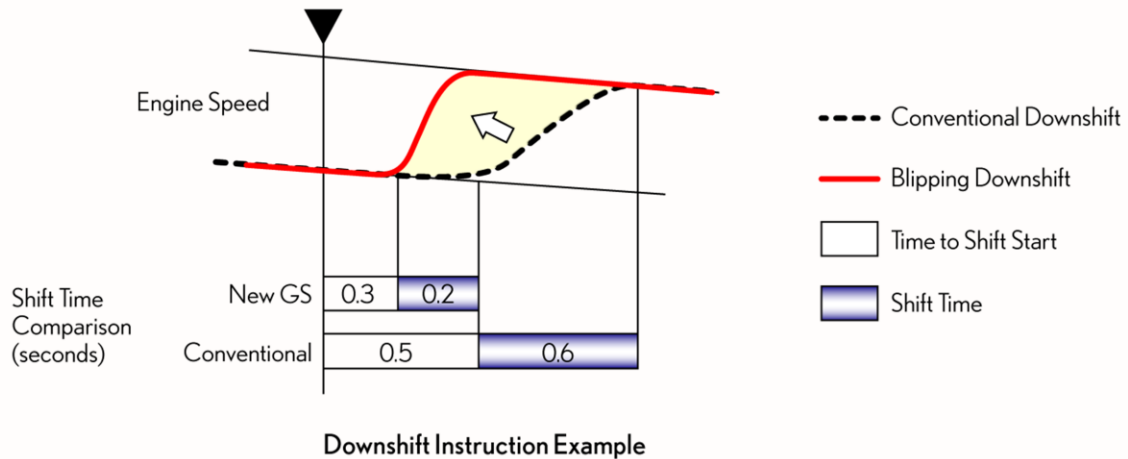

LEXUS

BLIPPING DOWNSHIFT CONTROL

- Blipping downshift control is activated in SPORT Mode (SPORT S Mode on AVS-equipped model), SPORT S+ Mode (AVS-equipped model only) and M-range paddle shift only.
- The clutch is quickly released under the hydraulic control system and, along with the neutral status of the transmission, the powertrain management system opens the electronic throttle.
- Engine speed increases and the transmission shifts down.
- The clutch is quickly and smoothly engaged under hydraulic control.

All-Wheel Drive

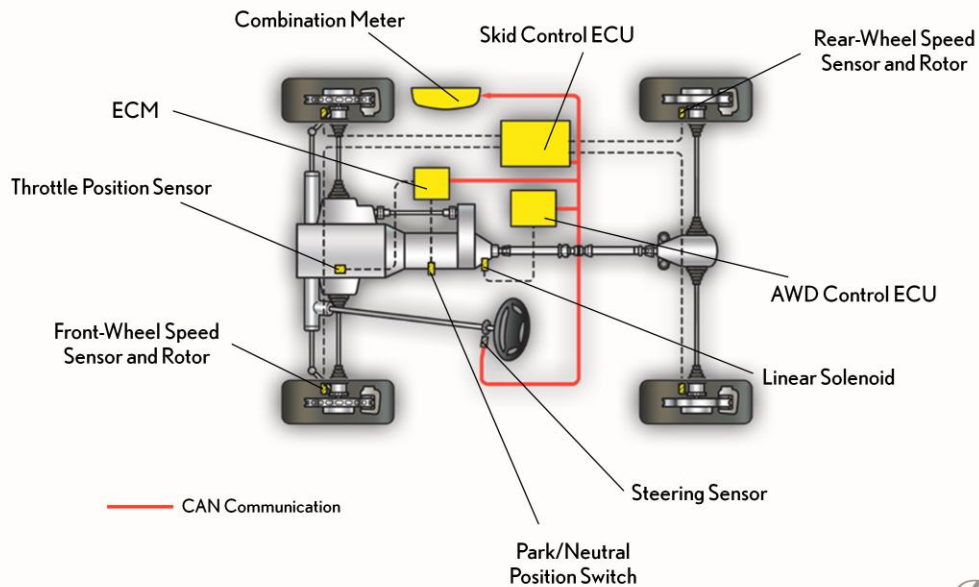

ALL-WHEEL DRIVE

- An available electronically controlled all-wheel-drive system is designed to enhance traction in a variety of driving conditions.
- The system can vary front-to-rear torque balance from 50/50 to as much as 30/70, depending on driving conditions.
- AWD models adopt the i-Four system electronic torque split full-time AWD mechanism.

UF1A Full-Time Transfer

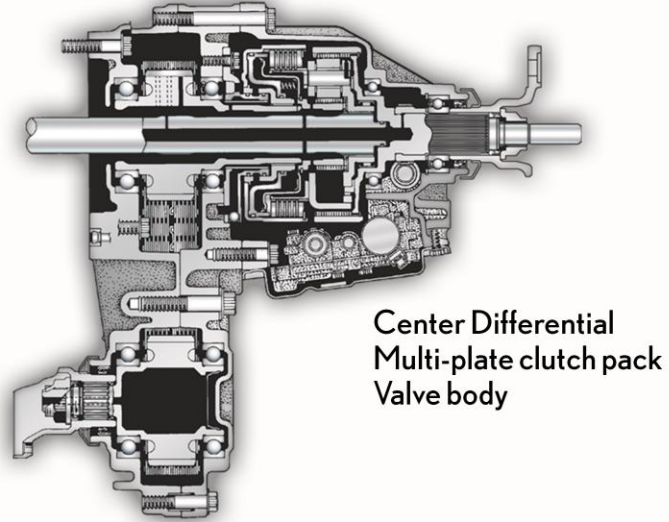

Center Differential
Multi-plate clutch pack
Valve body



ALL-WHEEL DRIVE

- Center differential is controlled electronically, enabling optimum drive force to be distributed to the front and rear wheels in response to driving conditions.



LEXUS HYBRID SYSTEM ADVANCEMENTS

ENGINE

- 3.5-liter 2GR-FXE 3.5L Atkinson-cycle V6 based on the 2GR-FSE engine as dedicated power unit for hybrid models.
- Atkinson cycle improves thermal efficiency by 12 - 14 % for top-of-class power output and fuel economy.
- D-4S direct + port fuel injection system lowers emissions
- Increased power to electric motors improves acceleration

TRANSMISSION AND MOTORS

- transmission frictional losses reduced for improved fuel economy using low-friction materials.

BATTERY

- Stacking battery modules in two tiers, moved forward by 7.5 inches (190mm) compared with previous pack.
- The battery's cooling design revised, contributing to enhanced cooling performance and fuel economy.

POWER CONTROL UNIT (PCU)

- double-sided cooling is used for the high-current transistors in the PCU.
- Integrating the DC-DC converter with the PCU-enabled installation within the engine compartment creates more space.

SYSTEM OPERATING MODES

- Special attention has been given to acceleration control logic.

2GR-FXE 3.5L V6

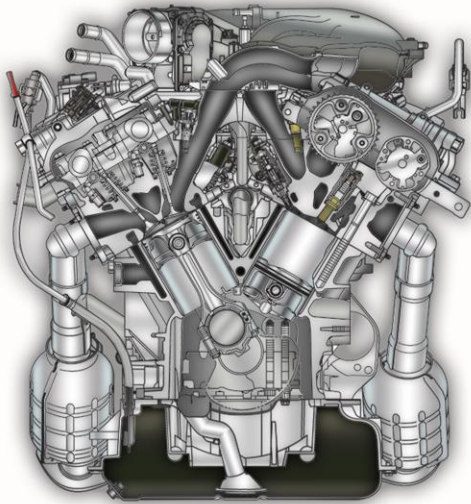

TABLE OF ADVANCEMENTS

Item	Comments
Atkinson cycle	Reduces intake pumping loss and improves engine efficiency.
Direct injection slit-type injector	Low penetration and high atomization targeted for improved combustion.
High fuel pressure changed from 1885 psi to 2611 psi (13MPa to 18MPa) by newly developed high-pressure pump	Injector body structure revised for improved durability. Noise reduction through high-pressure injector and high-pressure pump.
Idle port injection	Injection method during idling changed to port injection to improve NV performance.
Increased compression ratio (from 11.8:1 to 13:1)	Highest compression ratio by Lexus for large-displacement engine.
Moderate tumble intake	More substantial air/fuel mixing and reduced intake air volume for improved fuel economy and performance.



EXCELLENT FUEL ECONOMY

- Atkinson cycle engine has high expansion ratio / low compression ratio; helps improve efficiency by **35%** over previous Otto cycle engine.

NEXT-GENERATION D-4S CONTROL

- Fuel injector nozzle shape has been modified and includes side slits for better reliability and to accommodate more diverse fuel blends.
- Raising the injection pressure to 2611 psi (18 MPa) helps optimize combustion characteristics to improve fuel economy and power output.
- Location of port injectors has been optimized; by conducting port injection during idling, excellent quietness is realized.

LOW EMISSIONS AND LOW NOISE

- Lexus's first cyclone-type oil separator is used, helping reduce oil escape in blowby gas.
- Lightweight primary chain is used for the timing chain for reduced noise.
- Optimization of combustion characteristics and new ceramic catalyst.
- Improved corrosion resistance in the fuel system helps handle ethanol mixture fuels.

L110 Hybrid Transmission

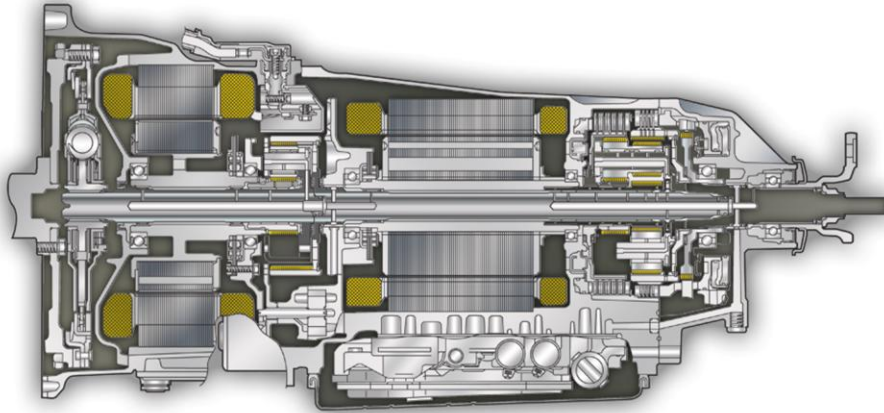

L110 TRANSMISSION

- The basic structure of the gear train is the same as that of the previous model.
- A power-splitting planetary gear divides the engine's motive power between MG1 and the ring gear.
- A 2-stage motor speed reduction device operates as a reducer for MG2.
- MG1, which mainly operates as the generator.
- MG2, which mainly operates as the motor.
- An intermediate shaft transmits engine power—which is split due to the power-splitting planetary gear—from the ring gear to the output shaft.
- A hydraulic control system controls the 2-stage motor speed reduction device.
- An electric oil pump generates hydraulic pressure when the engine is stopped:
 - This is a single-shaft construction, which is the same as one automatic transmission, comprised of MG1 and MG2, power-splitting planetary gear and 2-stage motor speed reduction device laid out on the engine crankshaft axis.
 - Gear ratios have been selected in consideration of both the driving performance and fuel economy.

Power Control Unit (PCU)

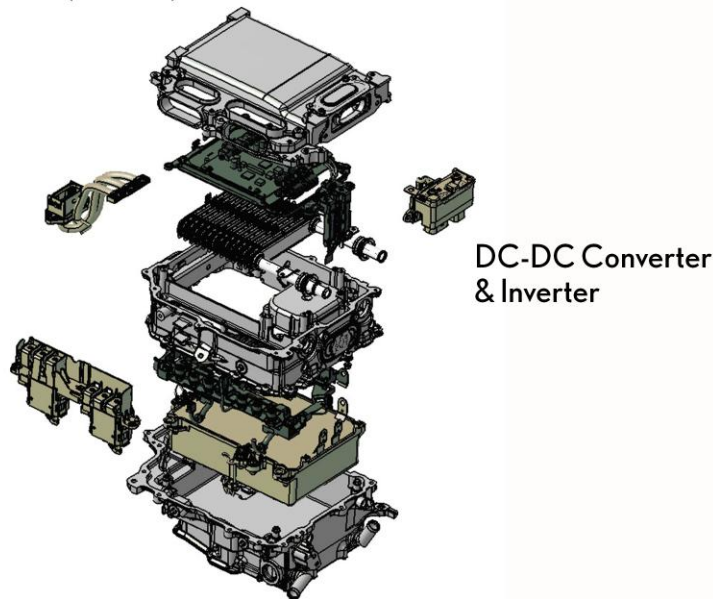

DOWNSIZING AND WEIGHT REDUCTION OF THE PCU (POWER CONTROL UNIT)

- Besides incorporating a double-sided cooling system for the PCU, thin film capacitors are adopted. In addition, integrating the DC-DC converter and PCU in a new structure, as well as other measures, helps achieve more compactness and reduced weight, contributing to low fuel consumption.
- Integrating the DC-DC converter with the PCU-enabled installation within the engine compartment creates space for more luggage.
- By incorporating the following, the PCU assures the same performance as that of the conventional PCU, while achieving more compactness. This also contributes to low fuel consumption:
 - A double-sided cooling system is adopted, helping to achieve more compactness and greater power density.
 - Adoption of a thin-film condenser helps to achieve more compactness.
 - The DC-DC converter and PCU are integrated, helping to save space.

PCU COOLING PERFORMANCE IMPROVED

- A double-sided cooling system is adopted for the inverter in the PCU, helping to achieve a compact size.

HYBRID ELECTRIC WATER PUMP FOR INVERTER COOLING

- Changing the structure and making the pump more compact, lightweight and efficient has contributed to fuel economy.
- Changing the drive system from the conventional "Normally Hi" to 3-stage control (Lo, Mid and Hi) has helped improve fuel economy.
- With downsizing and weight reduction, the weight has been reduced by approximately 30%.
- The installation location of the DC-DC converter is changed from the trunk to the engine compartment, while integration with the PCU (Power Control Unit) also contributes to increased luggage capacity.
- The following performance and functional improvements are achieved over the conventional 12-volt DC-DC converter:
 - The cooling system is changed from air-cooled to water-cooled and the internal layout of the DC-DC converter is optimized, helping to achieve more compactness.
 - The 150-amp power output block filter is changed to multi-stage, the shield structure adds strength and noise is lowered.

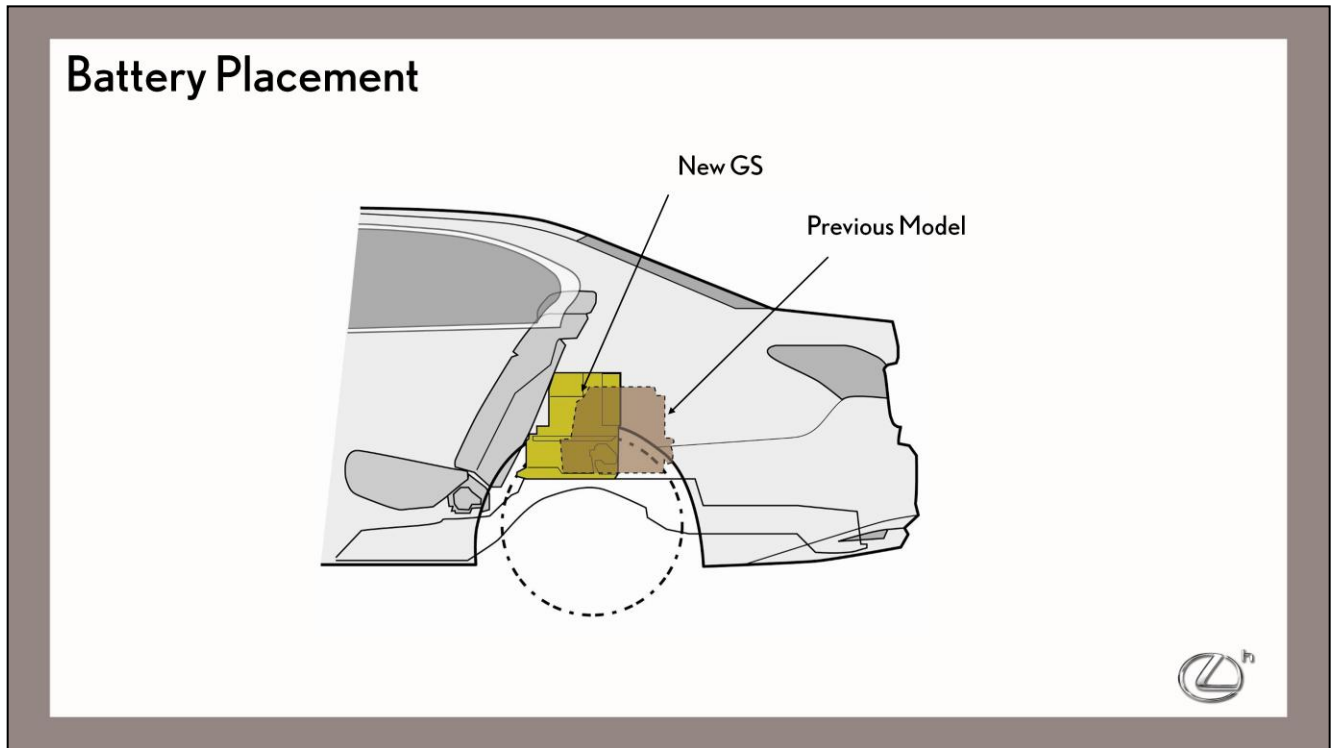

BATTERY PACK INSTALLATION LOCATION

The battery pack is installed in the luggage compartment behind the rear seats.

DOWNSIZING THE BATTERY PACK

- The 40-module battery pack is given a 2-tier construction, with six modules in the top tier and 34 modules in the bottom tier.
- To save space and improve maintenance performance, the junction block, monitor unit and other battery control electronic devices are laid out in the top tier of the battery pack.
- Air outlet duct moved to luggage compartment trim as an outlet passage for battery cooling air.
- Design contributes to the expansion of luggage compartment space.

STYLE



LEXUS

STYLE



BRAND MISSION

The new GS has established the following four essentials as its car-building mission:

- To establish the Lexus brand values (Joy and Leading Edge).
- To convey presence by means of expressing evolved L-finesse.
- To promote individuality that exudes advancement by drawing on the strong hybrid image.
- To reinforce presence in the E segment market.

LEXUS DESIGN DIRECTION

- The creation of simplicity that is intriguing.

EXTERIOR DESIGN MISSION

- Pursue further clarity in the expression of Lexus' original exterior design, setting it apart from other premium brands.

INTERIOR DESIGN MISSION

- Pursue an original interior centered around the unique Human Machine Interface.



BI-XENON HEADLAMPS

- Bi-xenon provides highly directional lighting to a greater distance than the previous model.
- HID lights gives a 63% reduction in power usage compared with the previous model.

ADAPTIVE FRONT LIGHTING SYSTEM

- Available AFS automatically directs the headlamp beam into the turn while cornering.
- The new system is designed to swivel both headlamps instead of just the inboard lamp to help prevent glare for oncoming vehicles and enhance visibility when cornering.



LED HEADLAMPS

Low beam; High beam; Turn signal; Near infra-red projector; DRL

- Standard on hybrid models.
- Excellent light distribution performance to help enhance long-distance visibility.
- Parabolic reflector offers diffused light distribution to help enhance short-distance visibility.
- Highly directional lighting characteristics enable beam projection to a greater distance.
- Improves energy saving by 53% (high beam) and 35% (low beam) compared with the previous model.
- Retains 90% or greater of its brightness after 15 years.
- A near infra-red projector reflector is used at the bottom of the turn signal lamp on vehicles equipped with Night Vision.
- 9-LED DRL helps gives a 66% energy saving compared to the previous model.

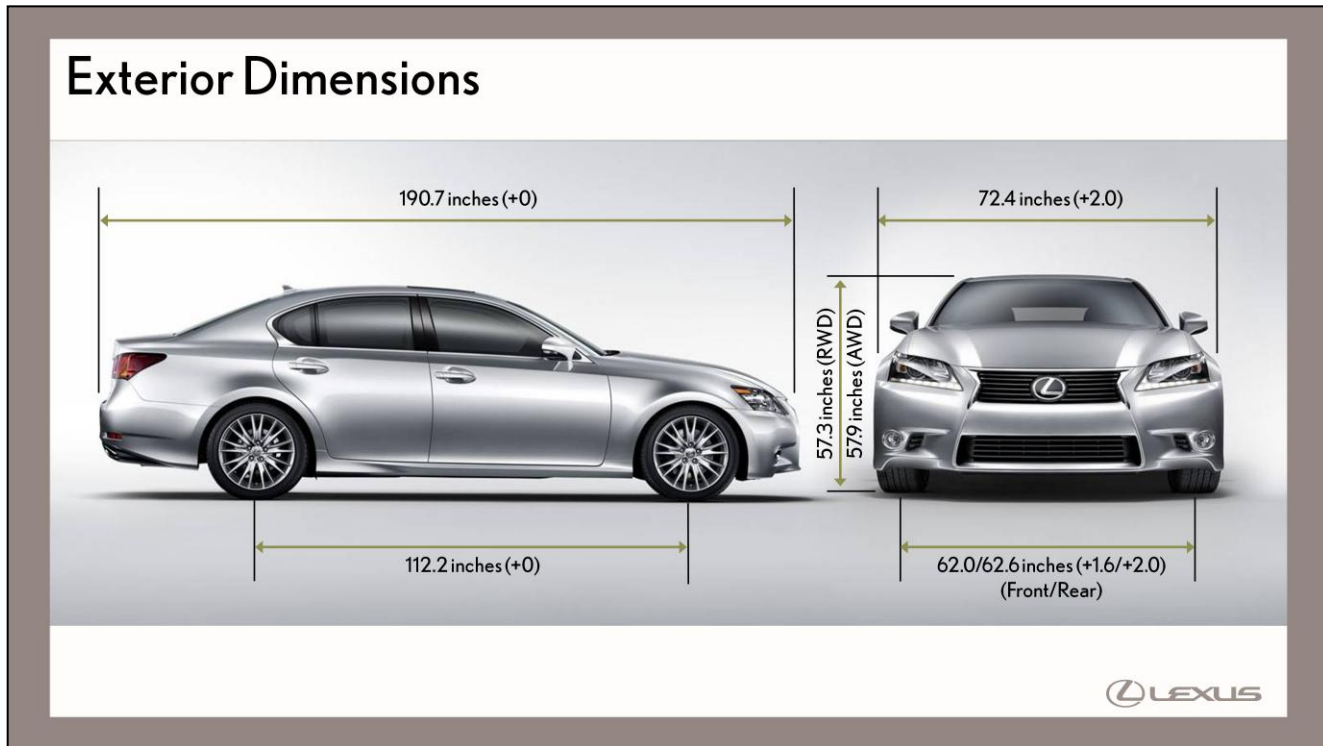

EXTERIOR DIMENSIONS

Measurement	Inches (difference)	Millimeters
Wheelbase	112.2 (+0)	2850
Tread Width (Front/Rear)	62.0/62.6 (+1.6/+2.0)	1575/1590
Minimum Ground Clearance	5.7 (+0.6)(gasoline) 5.5 (hybrid)	145
Overall Length	190.7 (+0)	4844
Overall Width	72.4 (+2.0)	1839
Overall Height [RWD]	57.3 (+1.2)	1455
Overall Height [AWD]	57.9 (+1.4)	1471

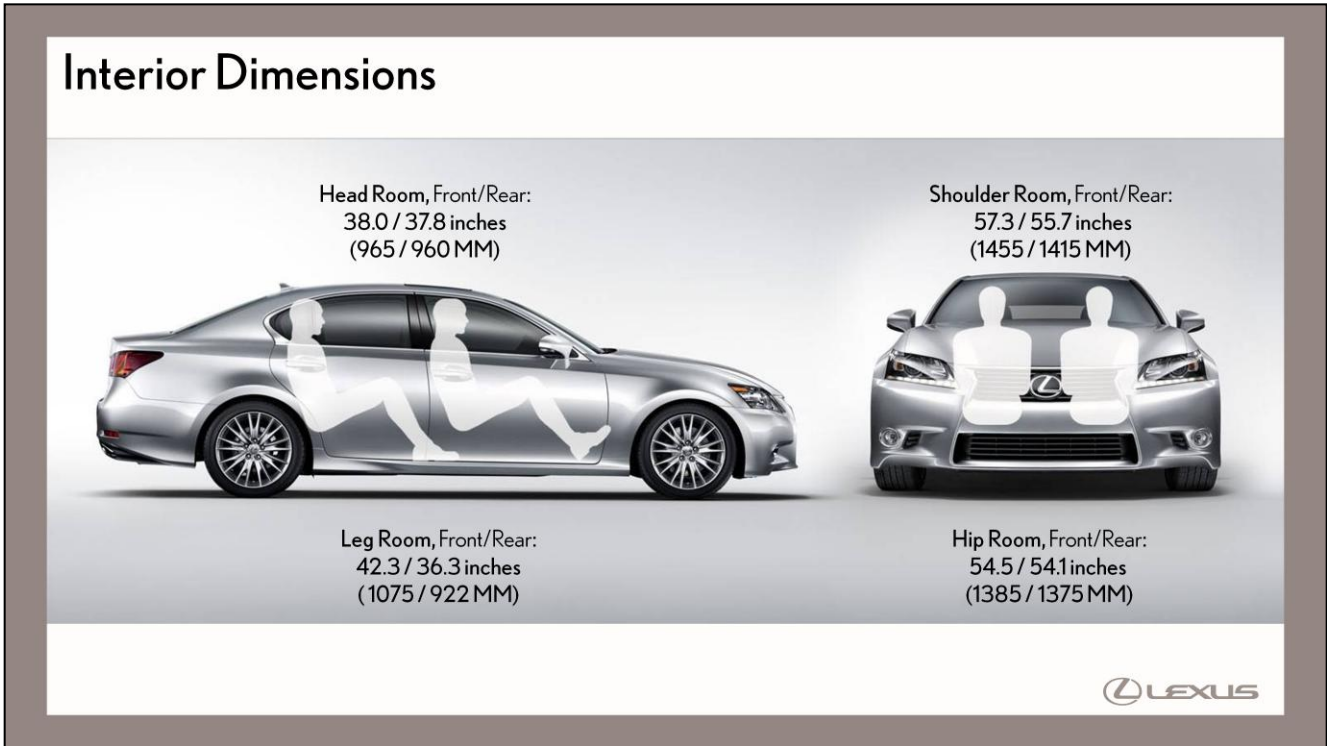

INTERIOR DIMENSIONS	Inches, FT / RR	(Millimeters)
Head Room. Ft/Rr	38.0 / 37.8	965 / 960
Shoulder Room	57.3 / 55.7	1455 / 1415
Hip Room	54.5 / 54.1	1385 / 1375
Leg Room	42.3 / 36.3	1075 / 922

CAPACITIES	Feet ³ (difference)	Meters ³
Cargo Volume		
GS 350	14.3 (+1.6)	
GS 450h	13.2 (+2.9)	

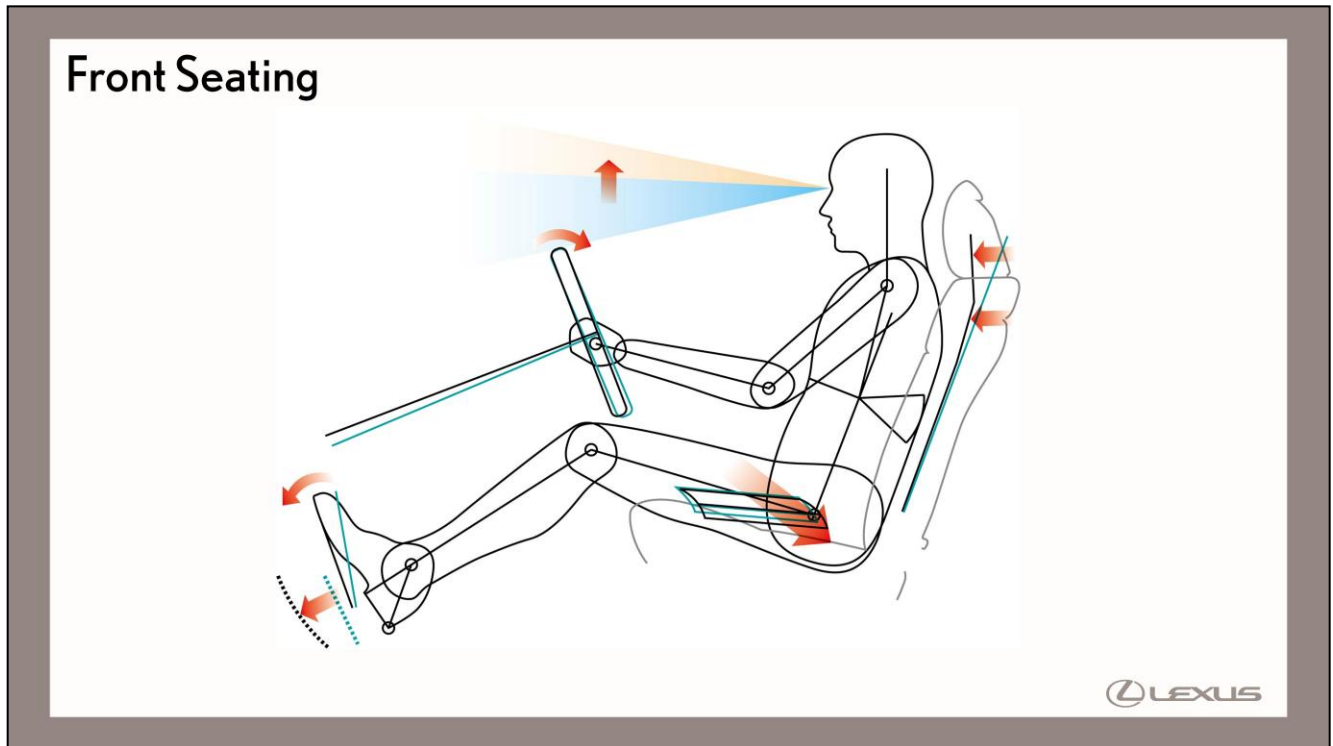

SEATING IMPROVEMENTS

- Steering column angle is 21° v. from 23° previous.
- Elevated seating position improves field of vision.
- Improved seat adjustment with available upper seatback adjustment.
- Brake pedal shape and size has been improved.
- Left foot rest shape and size has been improved.

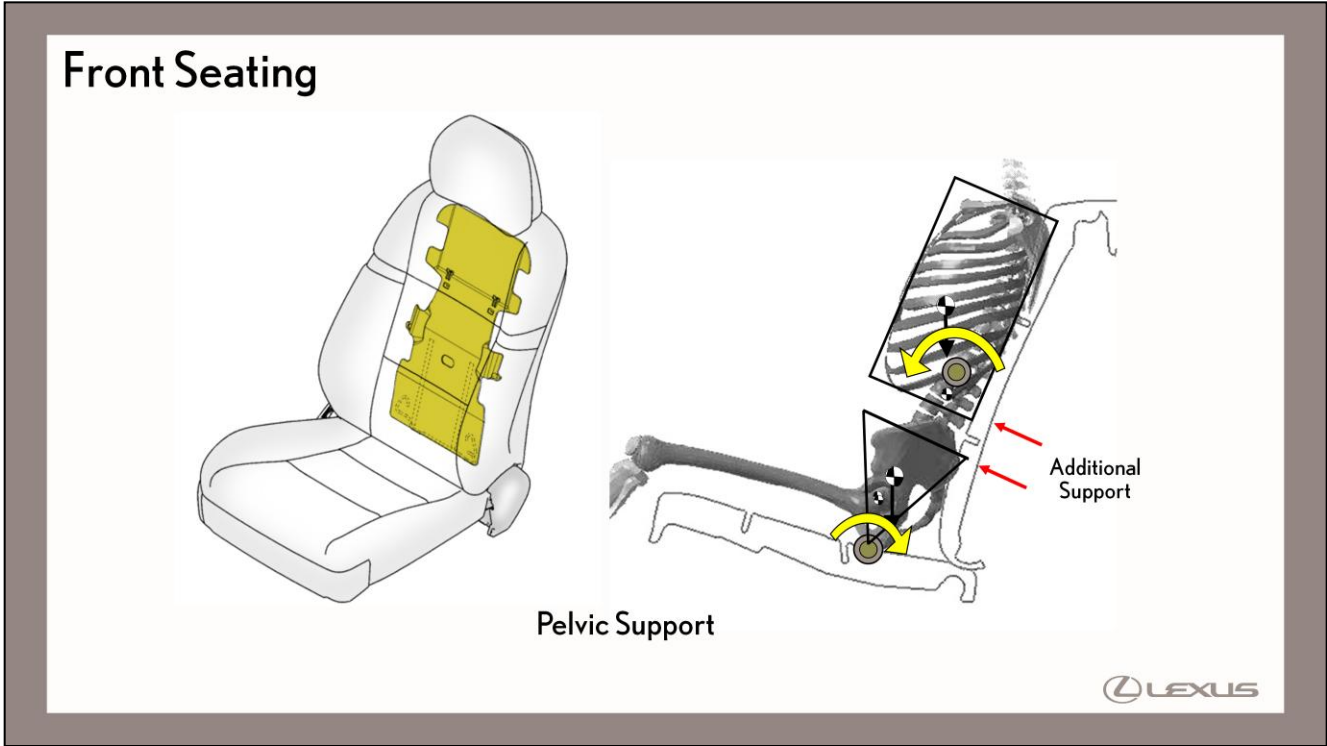

PELVIC SUPPORT

- Adjusts pelvic support at two levels
- world's first
- natural and comfortable posture by support of the lower back.

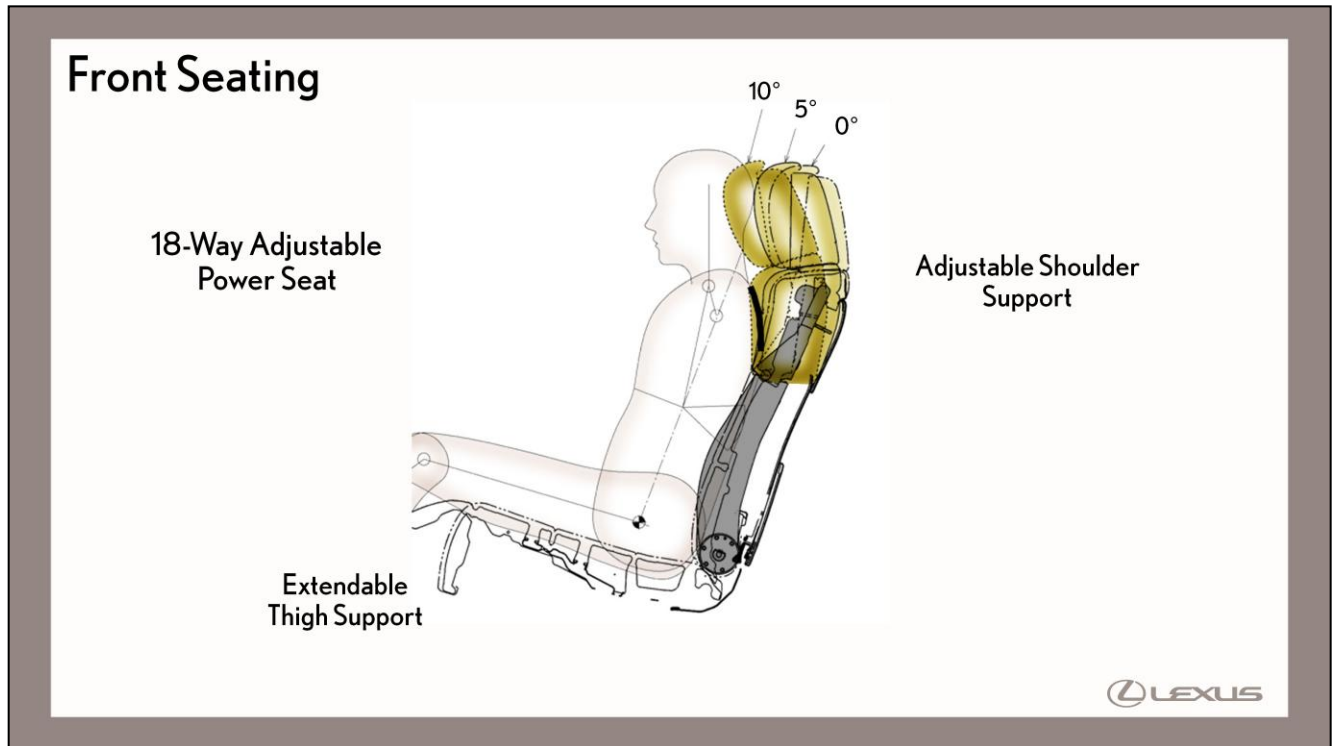

SHOULDER SUPPORT

- Making the upper part of the seatback adjustable helps to enhance the feeling of fit for the occupant's shoulders.
- A motor moves left and right links, which allows movement of the upper seatback.
- Closing the gap between the back upper section and seatback helps to enhance the feeling of fit.



REAR SEAT

- Increased knee space due to recessed front seat backs



SEAT HEATERS

- standard on Luxury
- seat heater switches in rear center armrest
- timer control automatically switches the heat level as the cabin heats up

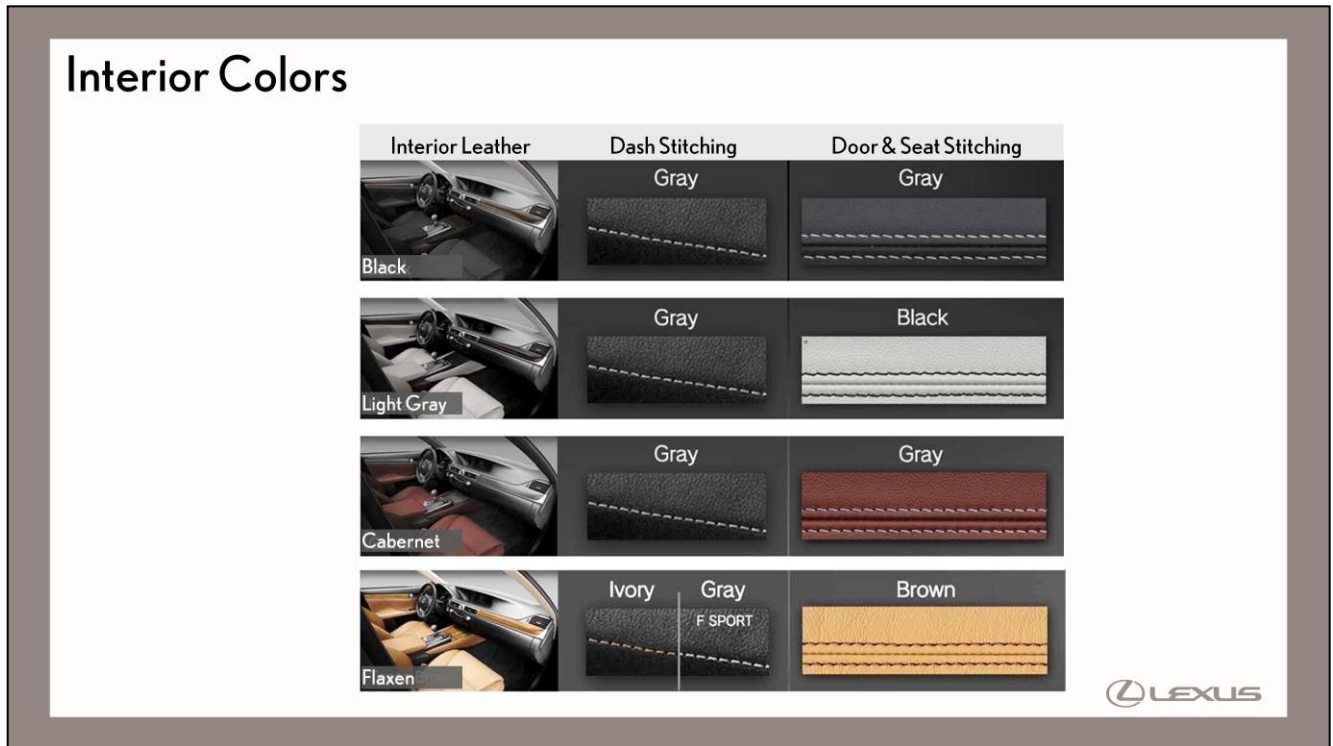

INTERIOR COLORS

- Traditional colors: Black (color code 24) and Light Gray (12)
- New color developed to project an aggressive look: Cabernet (30) *F SPORT only*
- New color that projects a luxurious image: Flaxen (54)
- New color developed to project an elegant and modern look: Saddle Tan *Hybrid only*

MATERIALS

- top of instrument panel, center console knee area, and front center armrest upholstered with colored stitching
- Base grade seat with perforations on center panel.
- Genuine semi-aniline leather on Luxury models.
- Diamond-shaped perforation exclusive to F SPORT for an aggressiveness look.



LED INTERIOR LIGHTING

- Interior LED illumination create an luxurious interior ambience.
 - map lamps
 - rear reading lamps
 - ambient door illumination
 - inside door handle illumination
- White LED high-light controls in the cabin for hospitality.

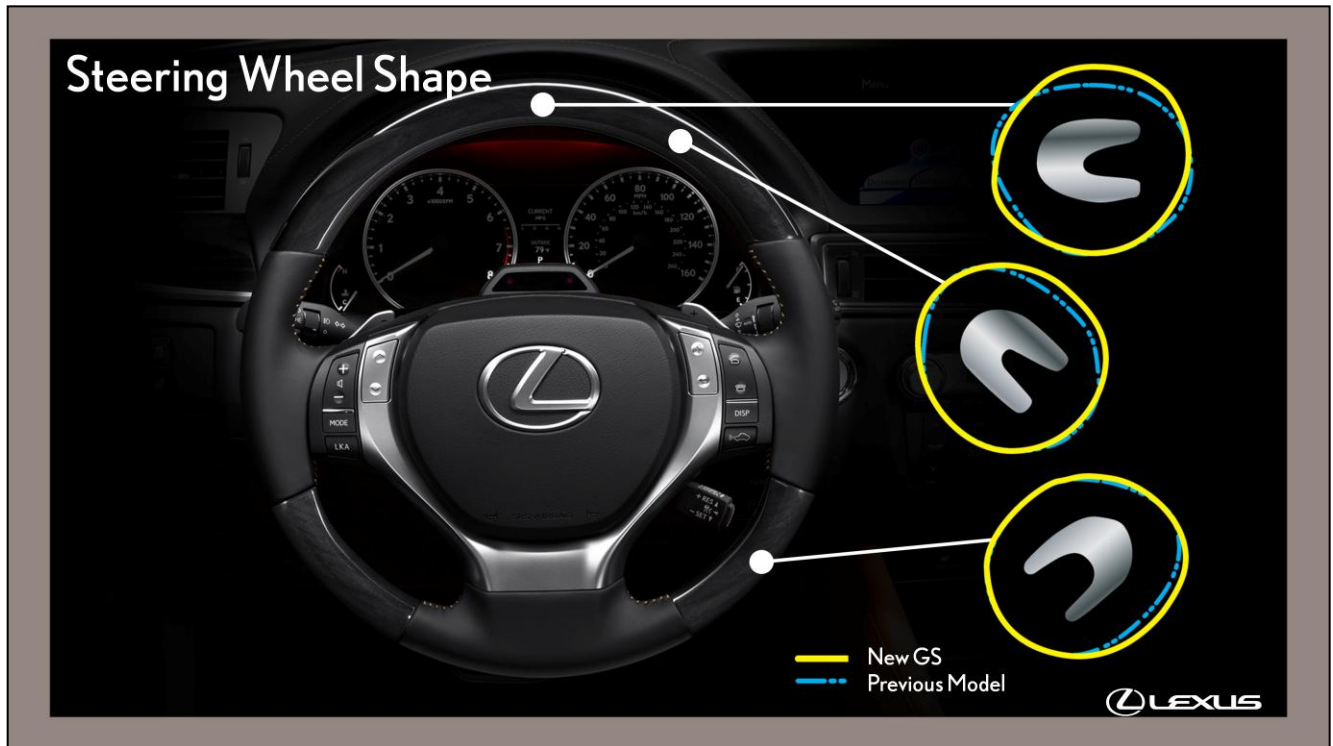

STEERING WHEEL SHAPE

- The cross-section shape varies around the circumference of the wheel.
- The reverse side of the spokes is thinner for more ergonomic fit.
- pressure distribution measured at driver's palms on the steering wheel during actual driving.
- Specially designed thumb rests for comfortable fit at the nine- and three-o-clock positions.



BAMBOO STEERING WHEEL

- Hybrid models use bamboo trim that includes a leather-wrapped steering wheel with bamboo inserts.



MOMENTARY-TYPE TURN SIGNAL AND WIPER SWITCHES

TURN SIGNAL FLASHER FUNCTION

- A momentary function allows the driver to signal a lane change without having to hold the switch down:
 - The turn signal lamps automatically flash three times when the turn signal switch is moved to its first stop.

CUSTOMIZABLE FUNCTIONS

- The default setting flashes the turn signals three times.
- The number of flashes can be set by the dealer to three, five or seven times.
- Cancellation is by repeat motion in same direction - cancellation direction can be reversed

WIPER SWITCH FUNCTION

- An independent switch to turn the available rain-sensing wipers ON or OFF is mounted at the end of the stalk.
- When the rain-sensing wipers are ON, an indicator turns on in green to notify the driver.
- Even during auto wiper operation, a one-time operation of the MIST feature can be used per wiper action.



CLIMATE CONTROL SYSTEM

- Lexus is promoting the development of air conditioning that senses the presence of occupants and conditions only the space they occupy in the car.

2-TIER INTERIOR/EXTERIOR AIR CONTROL

- Heating performance is enhanced and fuel consumption reduced by adopting a 2-tier interior/exterior air control structure.
- Circulates interior air while preventing fogging of the windshield.

3-ZONE INDEPENDENT TEMPERATURE AND AIR REGISTER CONTROL

- The vehicle's interior humidity, air temperature and glass temperature are measured using a sensor attached to the top of the window glass.
- Upper air mix can be set for coolness to deal with the effects of solar insulation and the lower air mix can be set for warmth.
- The air temperature for the rear-seat registers can also be optimally adjusted through exclusive air mix control.
- A multi-fan mode is used with three types of face modes, five types of foot modes and two types of bi-level modes.



MARK LEVINSON®

- The first Mark Levinson Premium Sound system was launched in the 2001 SC 430 & LS 430.
- The Mark Levinson Lexus audio evolution took a new, purposeful step with the introduction of the Mark Levinson Surround Sound system on the 2006 GS 300 and GS 430 luxury sport sedans.
- The debut of the 2007 LS 460 and the 19-speaker Mark Levinson Reference Surround system it came to house reveals the maturing relationship between Mark Levinson and Lexus.
- This painstaking design and development process continues to advance with the latest Mark Levinson offering in the 2012 GS.

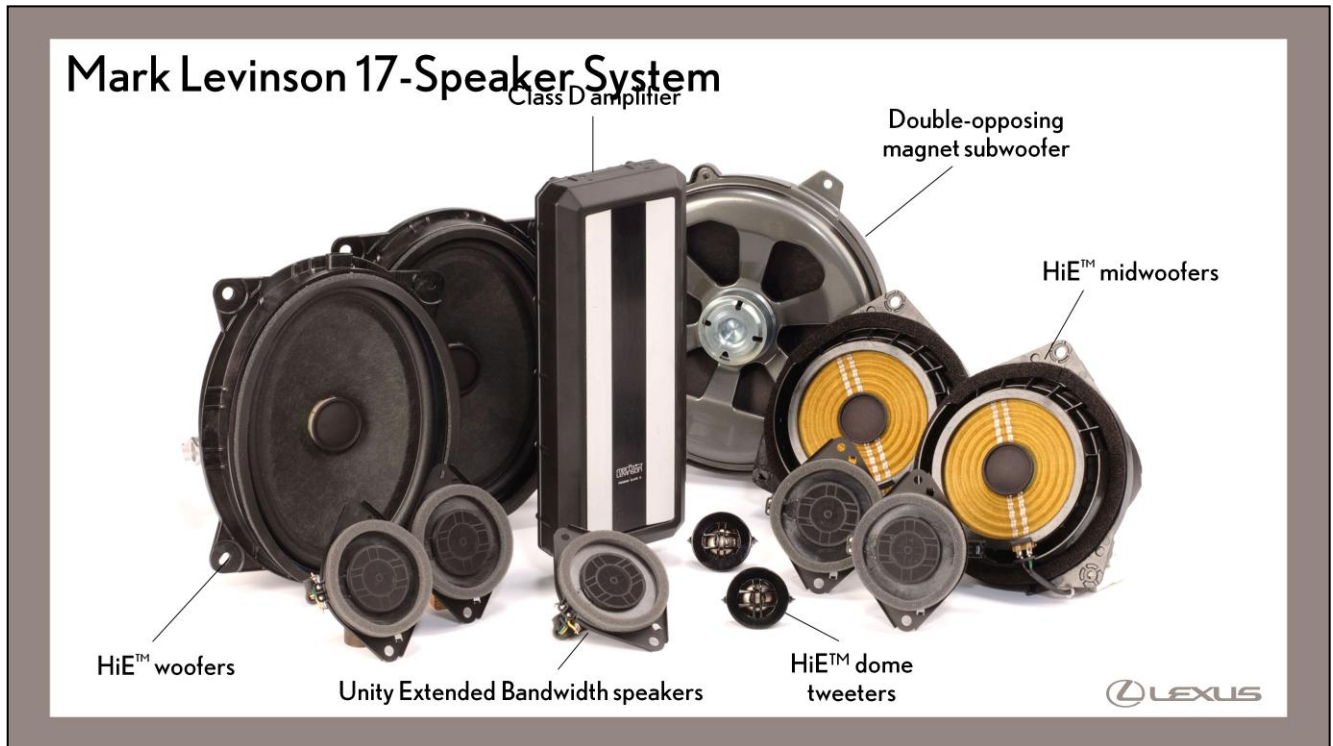

MARK LEVINSON Audio System

- 835-watt at 0.01% THD
- Class D amplifier for higher output, lower power consumed, lighter weight
- Five Unity Extended Bandwidth speakers (90mm midrange with 16mm tweeter)
- Two 180 x 250mm HiEfficiency woofers
- Two 25mm HiE dome tweeter
- Two 170mm HiE mid-woofers
- One 250mm double-opposing magnet subwoofer

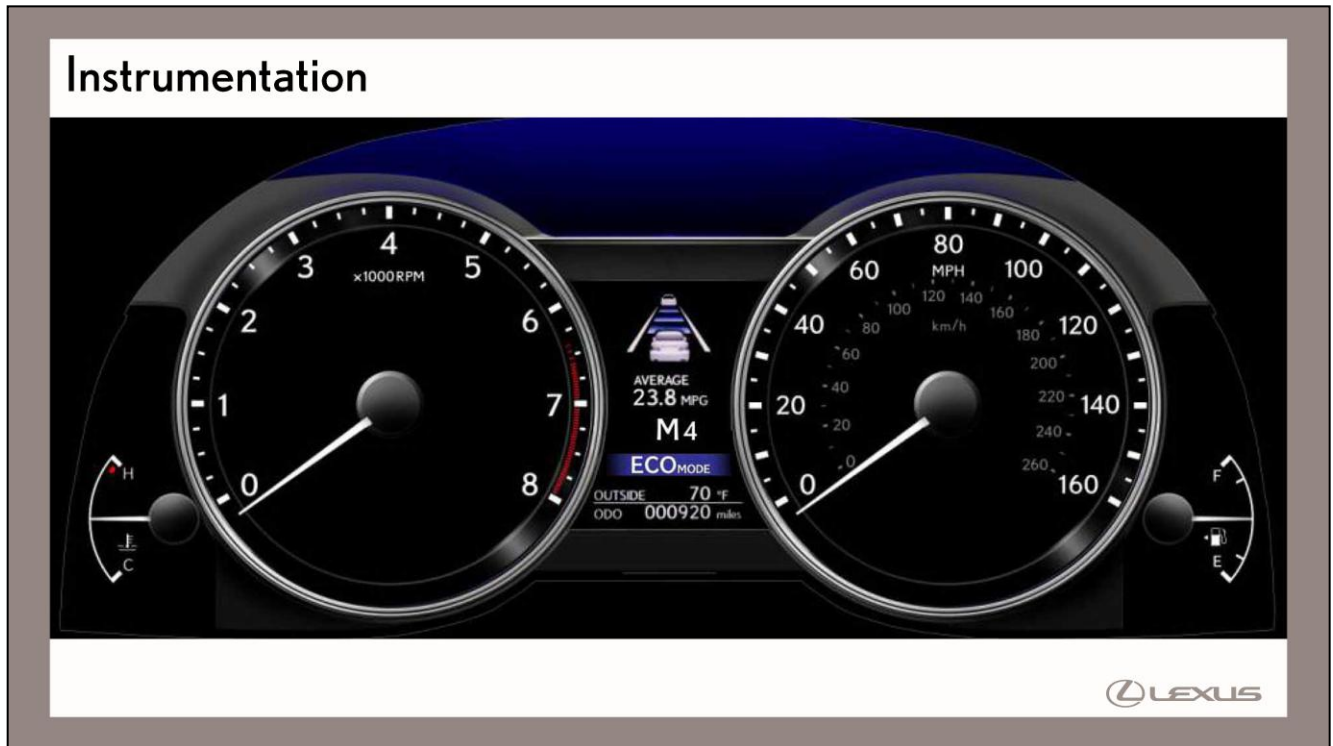

COMBINATION METER

- Large main gauges (internal diameter of 108 mm) help enhance visibility.
- The display area has a full scale up to 160 mph (260 km/h), expressing the high-performance potential of the vehicle.
- The meter illumination changes the color of light according to the drive mode.
- The hybrid model has a switching function that switches between Hybrid System Indicator and tachometer linked to the drive mode.

3.5-INCH COLOR TFT MULTI-INFORMATION DISPLAY

- A high-resolution color TFT display of dot size 0.222 mm between the tachometer and speedometer is used.
- Information and warning symbols are shown in fine detail, giving the display excellent visibility.

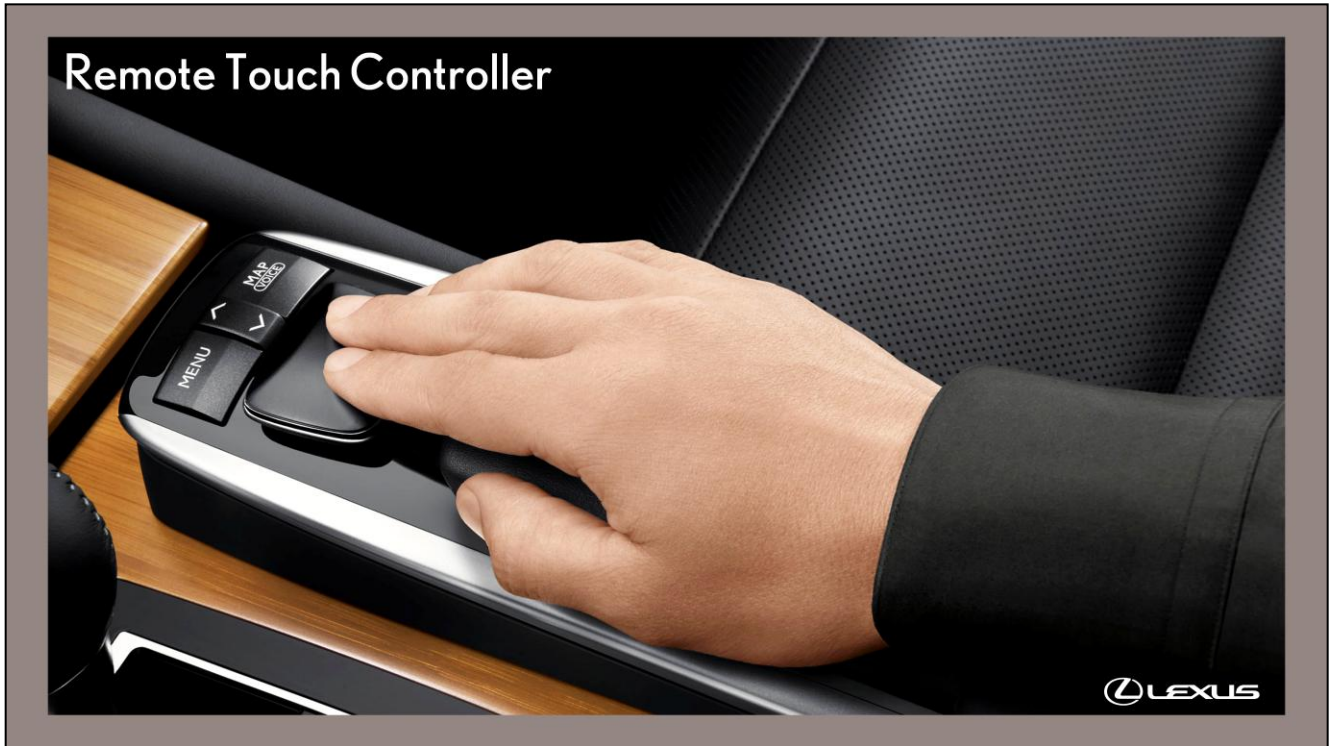

2ND-GENERATION HAPTIC JOYSTICK MECHANISM

- The controller has been changed from one that moves in an orbit on a spherical surface to a planar, slide-type controller.
- The ENTER switch on the side of the controller has been eliminated. ENTER is selected by pushing down on the controller.
- The controller knob can be moved in parallel to make a selection, and decisions can be made by pressing down the controller knob as if clicking a computer mouse.
- More intuitive operability like that of a computer mouse is achieved.

EASY-TO-USE LAYOUT

- The remote touch controller is placed further back than in conventional models and higher than the console surface, simultaneously achieving operability and armrest usability.
- A user-friendly design enables operations in a shorter amount of time with the driver's hand resting on the console and without any obstruction by the shift lever.



12.3-INCH DISPLAY

- 12.3-inch ultra-wide display is available with an enlarged screen ratio in the lateral direction.
- The display pursues not only a sense of security with the wide size, but also high resolution and high color definition.
- A dual screen display shows various types of information, such as audio or air conditioning screens, while also displaying the map screen.
- Switching between screens has been simplified to provide ease of use when driving.



LEXUS ENFORM® SERVICE OVERVIEW

Enform apps

- controlled by “VoiceBox” conversational voice-recognition
- Use “microphone” icon on NAV screen

ADDITIONAL APPS

- Facebook and Yelp have been added.

LEXUS INSIDER

- Receive, display, delete and playback audio data content distributed to Lexus users.
- Content obtained through DCM and XM® Satellite Radio tuner.
- A “Stop” button has been added to the Lexus Insider screen to halt playback; returns to the screen titled “Lexus Insider.”

DESTINATION ASSIST

- Function downloads information on points of interest (POI) that the driver requests by calling the Call Center operator.
- Destination information is downloaded to the navigation system via the Data Communication Module.

eDESTINATION

- A computer or smartphone can be used to access a database and downloaded using Data Communication Module.

- 20 folders with up to 10 POI destinations each, for a total of 200 POI destinations

MAINTENANCE REMINDER

- The Call Center uses vehicle information to notify the driver when it is time to visit the dealer for maintenance.



LEXUS ENFORM (APPS)

- Apps first download from the Internet to your phone, then to the vehicle itself.
- Takes advantage of the vehicle's high-resolution screen and uses Lexus protocol for safe driving with minimal distractions.
- Lexus Enform vehicles are factory-ready for subscriptions to a variety of innovative SiriusXM® services, including NavTraffic, NavWeather, Sports and Stocks.
- SiriusXM services require separate audio and data subscriptions.
- Applications for mobile phones, such as Internet radio and restaurant reservations, can be used with the vehicle's navigation system.
- Applications will be updated via mobile phones, connected by Bluetooth.
- Service is provided in the United States in the lower 48 states, Washington, D.C., and Alaska.

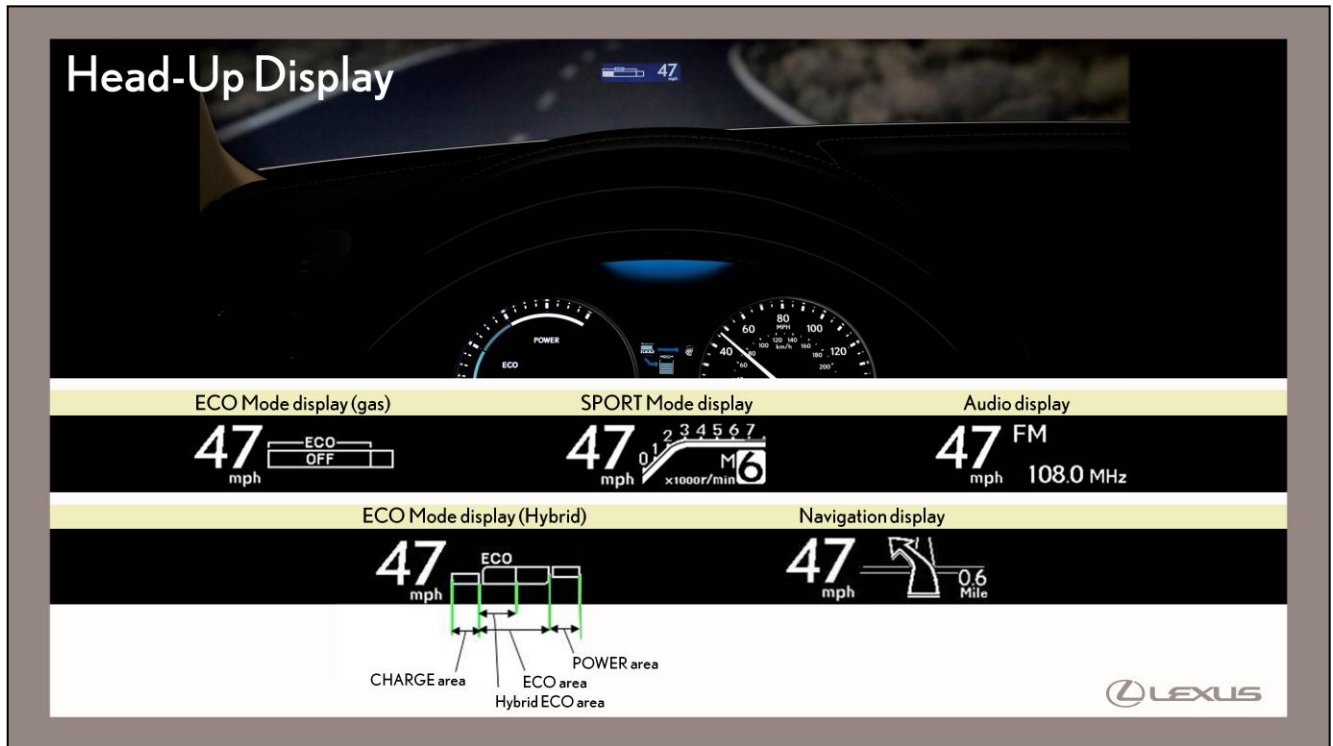

HEAD-UP DISPLAY

- To keep the display uniform with the rest of the Lexus lighting, white is adopted as the display color.
- Frequently checked items are displayed in high contrast, helping to achieve excellent visibility.
- Display contents include speed display, audio display, as well as the newly added SPORT mode (tachometer) display and ECO bar display.
- SPORT Mode (tachometer) display shows a torque curve along with engine rpm.
- ECO Mode display shows, in an easy-to-understand form, the eco-driving status against accelerator operation.
- Audio display, Lexus Night View display and navigation display can be set to OFF mode using the customize function.

SAFETY



SAFETY



FRONT PASSENGER KNEE AIRBAGS (SRS)

- SRS knee airbag located in the glove box door for the front passenger seat (Lexus first).

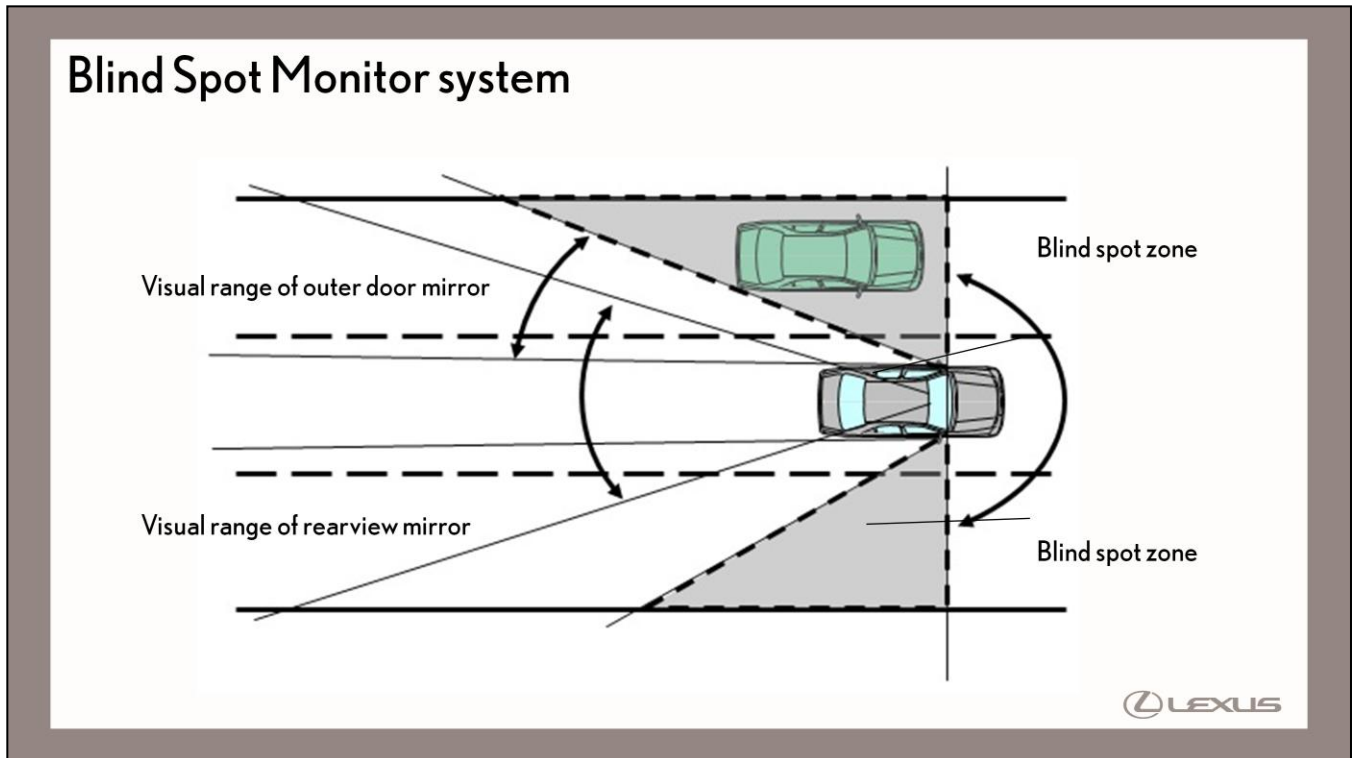

MAIN FUNCTIONS OF THE BLIND SPOT MONITOR SYSTEM

- Quasi-millimeter wave radar is used to detect vehicles traveling in an adjacent lane.
- If a vehicle is present in the blind spot zone and can't be seen in the mirrors, a mirror indicator illuminates.
- If the turn signal is operated while another vehicle is approaching, the mirror indicator flashes to warn the driver.
- Stationary objects, trailing vehicles in the same lane, vehicles traveling in a lane that is two lanes over and oncoming vehicles are not targeted by the system.



Thank you.